



GCSE Design Technology BBC Bitesize Information

**Use the website below to find further
information for each section:**

GCSE Design and Technology - Edexcel - BBC Bitesize

Mrs B Sadler

Name	
Class	

Contents Page

Core Content

- New and emerging technologies ----- Pages 5 - 12
- Energy generation and storage ----- Pages 12 - 20
- Developments in modern materials ----- Pages 20 - 23
- Electronic systems ----- Pages 24 - 30
- Mechanical devices ----- Pages 30 - 49
- Material categories and properties ----- Pages 49 - 56
- Design contexts ----- Pages 56 - 58
- Environmental, social and economic challenges ----- Pages 58 - 62
- Investigating past work ----- Pages 62 - 65
- Design strategies ----- Pages 65 - 68
- Communication of ideas ----- Pages 68 - 80

Materials

- Metals ----- Pages 82 - 98
- Timbers ----- Pages 100 - 124

NEA Project Skills

- Investigating ----- Pages 126 - 129
- Designing ----- Pages 129 - 133
- Making ----- Pages 134 - 138
- Evaluating ----- Pages – 139 - 141

- Answers ----- Pages 142 – 145

- Tests ----- Pages 146 - 149

Use the website below to find further information and complete the multiple choice tests for each section if you are unable to access the QR Codes at the end of the booklet:

[GCSE Design and Technology - Edexcel - BBC Bitesize](#)

CORE CONTENT
For Both Metal
and Timber
Students

New and emerging technologies

Companies are trying to save money, improve products, develop new materials and become more efficient. New technologies are developed to positively impact the manufacturing industry and society.

Impact on industry

Technology is evolving at a rapid rate and efficiency savings can be made through the use of new and emerging technology in manufacturing processes. This improves quality and speed of making while maintaining customer satisfaction. These efficiency savings can be passed onto the **consumer** through lower retail prices.

Automation

Automation has been developing in factories since the **Industrial Revolution**, with machinery being used to complete tasks previously done by humans. Automated machines are programmed to carry out a procedure multiple times, eg repeatedly creating the shape of a car door using a press, to improve production time. The cost of setting up machinery is high but, when they are operating, less waste is produced and running costs are lower. This is due to accuracy and scale of automated manufacturing.



An automated production line used for packaging

Robotics

The use of robots is just one part of automation. The difference between robotics and automation is that robots use **artificial intelligence (AI)** to collect information and improve the performance of a particular procedure. Robotics has proven popular because of their ability to increase efficiency and handle harmful materials that humans can't, but they are very expensive. Robots and robotic technology is constantly changing and improving, which can lead to jobs that were previously performed by low-skilled workers being replaced by robots or robotic technology. However, new jobs can also be created due to this new technology.



Because automation and the introduction of robotics can lead to low-skilled jobs being made **redundant** - this can lead to **unemployment** for some. As a result of redundancy, these workers may move cities or even countries to find employment. The movement of workers is known as **demographics movement** and can help labour shortages be filled, but it can also lead to the loss of people who are highly skilled.

With new and emerging technologies comes the need for employers to ensure their employees trained and their skills are up-to-date. This is known as **workforce skill set**. A workforce can range between low, medium and high skill levels. Many medium and high-level skilled employees associated with robotic employment need constant training in order to keep up with changes.

Science and technology parks are now commonplace in many countries, including the United Kingdom. They support businesses and research centres, like universities, and encourage collaboration, which can lead to faster technology development and, as such, faster product delivery to market.

Impact on enterprise

New ideas are continually emerging, but it is difficult to ensure these ideas are developed successfully. As a result, several ways have evolved to support the development of new products.

Privately-owned business

Many large companies started off as a **privately-owned** business. The owner makes decisions on the direction of the company and is not accountable to anyone else. There are benefits, including the ability to quickly adapt to changes in the market, but these companies often do not have the funding to invest in larger projects.

Crowdfunding

Traditionally, new businesses would borrow money from a bank to raise enough funds to develop a project. This is risky and, with **interest** payments, can be expensive. Crowdfunding uses websites to advertise products as investment opportunities, where people can choose to back a project with a financial donation if they think it will be **viable**. Backers are often rewarded with free gifts, discounts or a pre-agreed part of any **profits** if the product is successful.

Government funding

New businesses can benefit a country's economy but may not have the full funding to start up. Government may financially support a new business if it is believed that it would benefit the economy. In the UK, this government backing is known as **start-up loans**.

Not-for-profit

If the owner of an organisation doesn't cash-in the profit from the business but instead reinvests it into the business, it is known as a **not-for-profit** organisation. The profit is reinvested into the business to keep it running, develop the business or invest in new and emerging technology.

Impact on sustainability

Greater consideration is now given to ensuring that the materials and energy we use are **sustainable**. This includes where the resources come from and how they are disposed of at the end of their life.

Transport costs

Companies and **manufacturers** need to use transport to move goods and products, which can be one of the highest costs for a product, and also can cause lead to **pollution**. Transport costs impact on retail prices of goods and products, and designers might consider additional factors, such as how a change in material choice for packaging or smarter packing can impact cost. Modern vehicle design is also improving, with their shape and improved engines reducing fuel consumption.

Pollution

Pollution from the extraction of raw materials, transportation and manufacturing can all contribute to **global warming**. Examples of types of pollution include:

- noise pollution, eg from the use of heavy machines
- release of **greenhouse gases**
- water and soil contamination

Demand on natural resources

Finite resources are **non-renewable** and will eventually run out. Metals, plastics and **fossil fuels** (coal, natural gas and oil) are all examples of finite resources. Finite resources are popular as they are easily accessible due to strong supply chains and often have benefits for manufacturing particular products or for energy supplies. Companies have become more careful in their use of finite resources, and they now consider the **ecological footprint** caused by using such materials.

Mining for finite resources can have a drastic effect on the landscape



Non-finite resources

Non-finite resources are found naturally and can be replaced. Examples include natural timber, cotton and **renewable energy** sources such as solar, wind and tidal. Where trees are cut down for wood or hibiscus plants **harvested** for cotton, new ones can be planted in their place.



Farmer picking cotton

Waste generated

Manufacturers, designers and **consumers** should consider the waste generated when designing. To help with this, any or all of **'the 6 Rs'** could be implemented:

- **Repair** - Can the product be fixed instead of throwing it away into **landfill**? Repairing a washing machine can cost a lot less than buying a new one.
- **Reuse** - Can the product be passed on or its life extended by using it repeatedly? Reusable carrier bags from the supermarket are a good example.
- **Recycle** - Can materials such as metal, plastic and glass be collected and converted? Plastic bottles can be shredded into pellets to make new plastic bottles.
- **Rethink** - Can the design be remade using a different material? Using a quick-growing, renewable material such as cotton or bamboo would be an alternative to a non-renewable plastic-based fabric such as polyester.
- **Reduce** - Are there products that last longer or can be recharged? Can the miles the product has to travel be cut? Or could **rechargeable batteries** or locally-sourced products be used?
- **Refuse** - Think twice before buying a product with wasteful packaging or a large carbon footprint

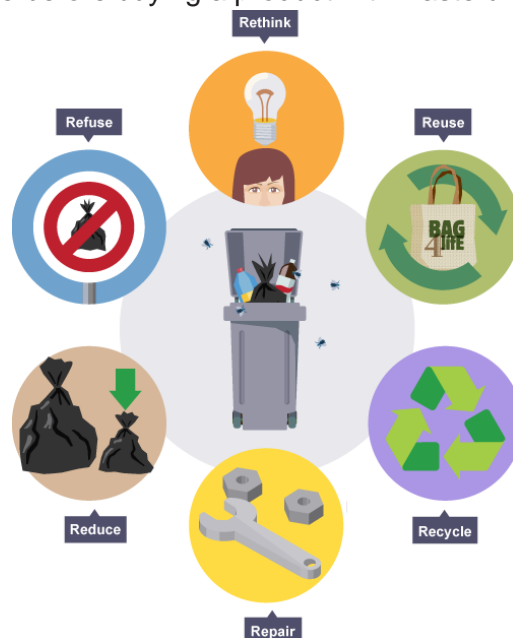

Impact on the environment

Modern companies are encouraged to be less wasteful and more considerate of how they affect the natural environment.

Pollution

Pollution is caused when harmful substances are released into the natural environment. Pollution can occur in the air, water or natural land. Legislation has been brought in to help with this issue. For example, in the UK cosmetic products can no longer contain plastic **microbeads** as these were previously polluting the ocean. Harmful products, such as batteries, should be disposed of correctly, and companies are being encouraged by **government incentives** to recycle waste wherever possible.



Waste disposal

It is important to ensure that companies work in an efficient manner. This includes increasing the speed of production, reducing errors and reducing waste, which can be done by utilising **automation** or **computer aided manufacture (CAM)**. Implementing **quality control (QC)** checks ensures that errors are quickly spotted and provides the customer with reassurance. Designers need to design with disposal in mind, so that products can be dismantled for parts, for full recycling or for reuse. This will reduce the waste that ends up in landfill.

Material separation

Oil and metals are **raw materials** that are **finite resources**, meaning that they will run out. Separating materials for recycling or reusing them is one way to ensure less ends up in landfill and instead is available for future generations.

Governments and local councils provide recycling bins or bags to encourage households to recycle their waste. Mixed waste has to be sorted, with automated machines making use of new technologies to separate materials to be cleaned, ready for processing into new products.

Transportation of goods around the world

Manufacturing processes in factories or the use of day-to-day products like cars can cause harmful chemicals, such as carbon monoxide and nitrogen oxides, to be released. These chemicals pollute the air and natural land. Worldwide environmental awareness has led to limitations on the levels of pollution and emissions of **greenhouse gases**, as well as targets on **renewable energy** generation, to try to stop **global warming**. The development of more efficient electrical products, such as low-energy lightbulbs, and better building insulation has cut down on energy costs. Some countries offer incentives to increase the use of emission controls, electric vehicles and energy-saving devices, such as better insulation and automatic shut-off devices.

Packaging of goods

How materials and resources are disposed of is carefully monitored and managed by local councils. Households are encouraged to recycle waste items where possible, including products made from various materials such as hard plastics, paper and steel. In 2016, the UK recycled 25 per cent of household waste, with the target of 50 per cent in 2020. All other waste goes to **landfill sites**, which release harmful gases that pollute the surrounding air and soil.

Impact on people

Technology is all around us and impacts on how people work, interact and live:

Workforce

With the advances in technology, flexible working and working from home has become more common.

Advantages for the workforce	Disadvantages for the workforce
The employee can choose where they work from, eg home, cafe or the office	Home and work life intertwine, which may impact on productivity or affect personal and professional relationships
Productivity can improve	
Reduced costs for companies as they require less office space	

Consumers

The latest trends in products create a demand for them, eg mobile phones are often very popular when first released. **Manufacturers** need to respond to this demand and increase production, which puts a strain on **finite resources**.

Children

Technology use can have advantages and disadvantages in children.

Advantages for children	Disadvantages for children
Technology can help support learning and encourage broader outlooks and creativity	It could contribute to health problems if excessive use leads to a poor active life

People with disabilities

Disabilities can be visible or invisible, and technology can help people who have a disability and improve their quality of life. An example is how developments in 3D printing mean that 3D printing machines are more readily available and are being utilised to help other people, eg to produce low-cost prosthetics for people in **developing countries**.



3D printed model of a prosthetic hand

Highly-skilled workforce

The **automation** of workplaces has led to an increase in roles and opportunities for skilled workers, but in some areas it has led to a decrease in job opportunities, as machines have **taken over the jobs previously done by humans**. Automation has streamlined the manufacturing system by increasing production and reducing errors.

Impact on society and culture

Society is defined as a group of people living as a community or organised group for a common purpose, and societies can exist within a workplace. The use of technology within societies is common and has its advantages and disadvantages.

Changes to working hours

The internet has made staying connected to work much easier, which can lead to a change in working hours for those who work in organisations that allow remote access to work systems. This also means that workers can pick their working hours to suit their personal needs, like childcare, which could lead to high job satisfaction. This can, however, blur the boundaries for employees between work and personal life, which can lead to a decrease in efficiency and potential negative impacts on workers' personal lives.

Remote working

When a worker works away from the office it is known as remote working. A worker may choose to work from home or a cafe. The internet allows people who work in organisations which allow remote access to work systems. An advantage is flexibility in working hours to suit personal needs. A disadvantage is a worker can become isolated with limited interaction with co-workers.



Use of video conference meetings

The use of video calling has become common through mobile phones and increased internet connection speeds. Video conferencing is not new to the business world but these advances in technology have meant the quality of video and audio has significantly improved. Many businesses are choosing to have video conferences as it reduces costs of travel, especially where meetings need to be had with business in different countries.



Internet of Things (IoT)

When digital products are connected together using the internet it is known as '**Internet of Things' (IoT)**, eg remote access to a TV set top box to record a TV programme. IoT products rely on the internet, which can experience connection problems making reliability an issue.

Population movement within the EU

Members of the **European Union** are free to live and work in any state of the EU. When people move from one country to another to live and work it is known as migration.

In 2016, the UK voted to leave the EU, commonly known as 'Brexit'.

Social segregation

It is common to find multicultural societies in developed countries, with people from different countries, faiths and backgrounds all living together. When people of one ethnicity live in one area it is referred to as 'cluster' living and **social segregation**. Social segregation leads to limited interaction with people from different backgrounds and sometimes difficulty accessing medical care, secure jobs and schooling.

Production techniques

Developments in production techniques have led to a variety of production methods being created to improve efficiency by saving time and cutting costs.

Standardised design and components

When a **manufacturer** uses the same component across a number of products it is known as standardised design and **components**. For example, car manufacturers owned by the same company often share components as it can reduce development and production costs, and increase the speed at which a product comes to market.

Just-in-time (JIT) manufacturing is triggered by a customer order. The correct amounts of materials are ordered in to cover the order, and these arrive just as they are needed by production. This saves money on storage, reduces waste and ensures there is no money wasted producing stock that will remain unsold. There are disadvantages to the system in that, if any part of the product cannot be sourced, **clients** have to wait for their order to be produced.

Lean manufacturing is a Japanese concept, based on minimising costs and maximising efficiency by cutting down on waste and the amount of materials and energy used in production. This is done by adapting designs and making changes to the production process. For example, to reduce waste, a packaging net could be redesigned to include a tessellating pattern or, to improve efficiency, changeover times between production runs could be reduced.

One-off production

Prototyping can be used for testing and in-user trials. As well as this, **bespoke** specialist machines and vehicles can be made for a client using one-off production. Specialist workers and production aids are needed. This can produce high-quality and original objects, but they are often expensive to make and buy and highly skilled workers are needed to produce them.

Batch production

Batch production is where many items of the same product are produced, such as mobile phones and TVs. A range of products can be made, particularly ones that are regularly changed, but time is lost when **retooling** and skilled workers are needed. When a product is made in a batch, it is often far cheaper per product than making just one.

Mass production

Mass-produced products are manufactured in large volumes, and are often made by automated machinery with **assembly line** workers used to fit parts together or add standard components. Products are kept low cost as a large number are made and bulk materials and components are cheaper to buy. There is, however, a large cost in setting up such an assembly line.

Continuous production

Continuous production takes place 24 hours a day, 7 days a week and, in some cases, 365 days a year. It can produce huge volumes of a product at a low cost but it is limited to a small range of products, and as with mass production it is expensive to set up.

Informing design decisions

It is important for designers to consider a wide range of perspectives when designing a product and to consider the many scenarios that affect the product's life.

Planned obsolescence is the practice of designing products that will have a limited **life cycle** and that will become obsolete and require to be replaced, such as disposable razors. Modern mobile phones are a good example as they need continual software upgrades and they are soon replaced by new better-performing models. Planned obsolescence is generally bad for the environment as it creates more waste.

Design for maintenance is a term used when designing products that are more **durable** and have spare parts available to mend and maintain them. This is only possible with low-tech or **modular** products that don't require a great deal of skill to repair. For example, a push bike can be regularly maintained, with parts such as pedals and chains being replaced when they are damaged.

Design for disassembly is a concept that when a product has reached the end of its life it can be taken apart and parts **reused** or **recycled**. For instance, a stool could be unscrewed to allow the plastic seat and steel legs to be recycled.

Environmental design is something designers are increasingly considering by:

- making products from **renewable** materials, such as paper straws instead of plastic, to create less waste material
- transporting materials in a more efficient way to cut down on emissions of **greenhouse gases**
- cutting down the use of **finite resources** for use in production and for energy supply; improving the overall environmental impact of a product

Energy generation and storage

Energy generation and storage have a huge global impact on our lives - from decisions about the use of fossil fuels and their effect on our environment, to the development of cleaner, more-modern ways to create and store energy.

Fossil fuels

Fossil fuels are a finite resource, meaning that they cannot be replaced once extracted from the ground. In 2015, 80 per cent of energy consumed in the world came from fossil fuels. In early 2018, the UK's dependence on fossil fuels was at a low of 77 per cent. Examples include:

- coal
- natural gas
- oil

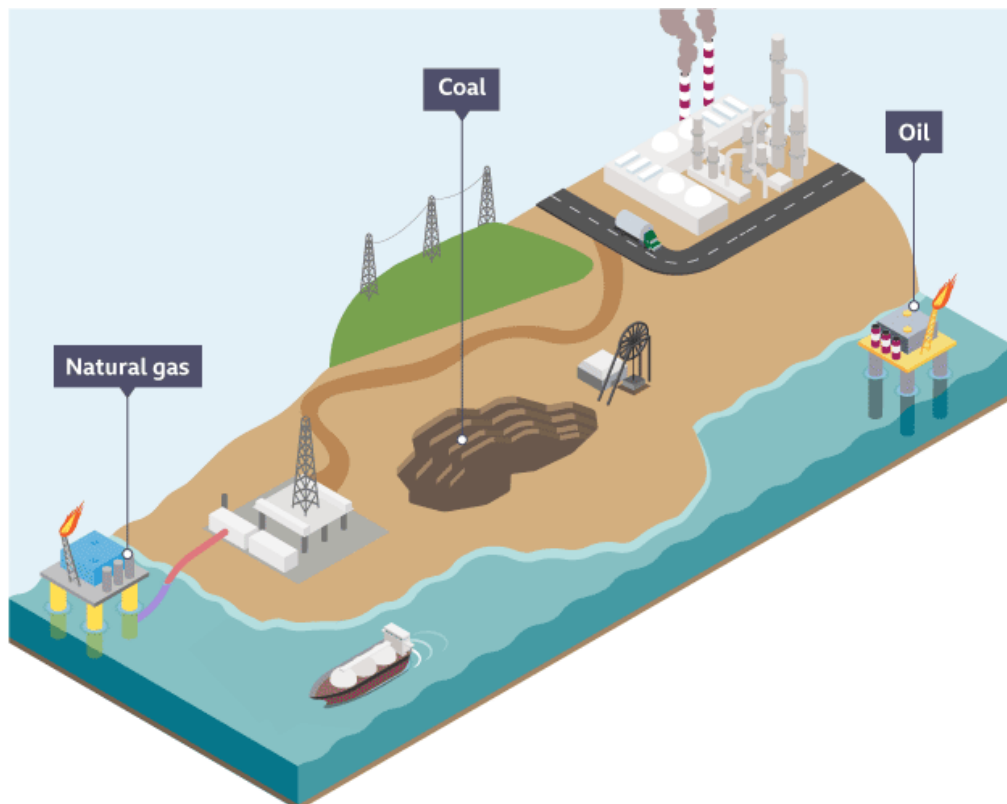

Coal

Use of coal for electricity generation in the UK has fallen since 2012. This energy is created through the burning of coal, which is usually crushed first. The hot coal heats water, turning it into **steam**. The steam builds up to a very high pressure and this is used to spin a **turbine**. The turbine is connected to an electrical **generator**, which creates electricity.

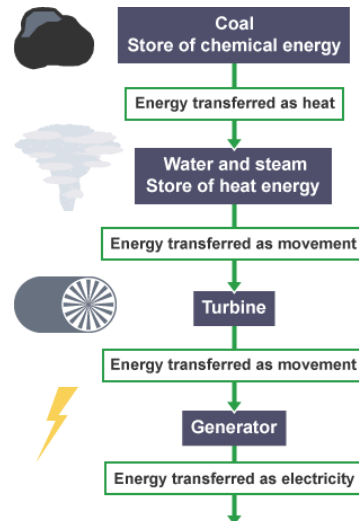

Advantages of coal	Disadvantages of coal
Enough coal on Earth to last hundreds of years	Produces carbon dioxide when burned, contributing to global warming
Produces high amounts of energy	Damage is caused to natural land when mining takes place

Natural gas

In 2017, **natural gas** accounted for over 30 per cent of the UK's energy production. It is used for heating and cooking and is one of the main sources of powers for electricity production in the UK.



Gas hob

It is most commonly produced off-shore and transported through pipelines to a gas-powered electricity power station. In the UK there are **shale gas** deposits. Shale gas is obtained using a process known as **fracking**, which involves cracking large rocks underground. There is a lot of discussion about whether or not this process should be used, with concerns around damage to land and the release of harmful gases.

Advantages of natural gas	Disadvantages of natural gas
It emits less carbon dioxide than coal or oil	Gas is highly flammable - if there is a gas leak, an explosion can easily happen
The UK has shale gas deposits	Extracting gas might cause the pollution of water

Oil

Very little of the UK's electricity comes from oil as it is mainly used for fuel or is [turned into plastics](#). However, a very small amount is burned to heat water, creating steam, to generate electricity.

Advantages of oil	Disadvantages of oil
A small amount of oil can produce a lot of energy	Creates significant air pollution when burned
It is relatively easy to store and transport	Considerable impact on water, land use and disposal

Nuclear power

In 2018, nuclear energy generated around one fifth of the country's electricity. A huge amount of energy can be produced through the nuclear process using a relatively small amount of **uranium**. The energy is produced as heat through the [fission process](#).

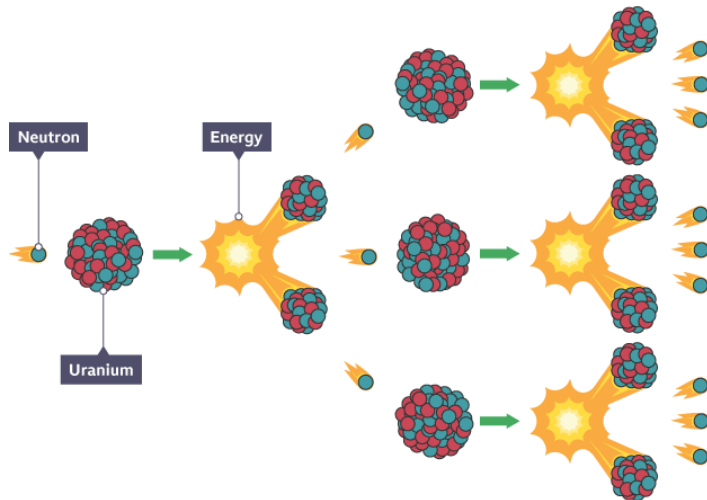

Atoms are split, and this energy is used to convert water into super-heated **steam**. This spins **turbines** connected to electrical **generators** to produce electricity.

Advantages of nuclear power	Disadvantages of nuclear power
No harmful gases are released in the process	Nuclear power stations have to close after around 40 years of use when the uranium becomes less efficient at heating the water
More efficient than fossil fuels	Disposal of uranium is difficult and costly
	Cost of nuclear power stations is very large

Renewable energy

In 2018, around a third of the UK's electricity was generated by **renewable energy** sources. They are a **non-finite resource** as they harness the Earth's **natural resources**. Examples include:

- wind
- solar
- tidal
- hydroelectric
- biomass

Wind

Wind energy is harnessed through the use of wind turbines - tall towers with three propeller blades (vanes) that appear frequently around the UK.

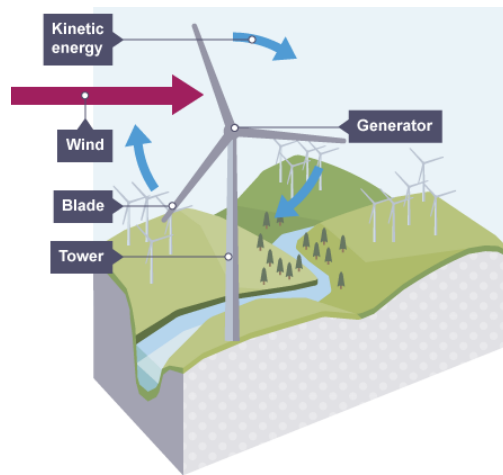

The blades turn with the wind, driving a **generator**, which produces the electricity. While there are many dotted around the countryside as single towers or in a small group, they are now more commonly grouped together off-shore in large quantities to form a wind farm.

Advantages of wind	Disadvantages of wind
Wind energy is constantly available and sustainable	When there are periods of low wind, little or no energy is produced
There is no cost for wind and the running cost of a wind turbine is relatively low	They cost a lot to build and put in place
	Some people do not like the look of wind turbines or feel that they spoil the natural landscape

Solar

Solar panels are made from **photovoltaic** cells, which harness the Sun's light energy and convert it into electricity. Solar power provides **clean energy** from a plentiful supply, but there is still considerable development work to be done to try to make solar panels more efficient. The placement of the solar panels is also very important to ensure they track the path of the sun and harness the optimum amount of solar energy.

Advantages of solar	Disadvantages of solar
Clean, renewable energy source	Some people do not like the look of solar panels or feel that they spoil the appearance of a building
Reduces household energy bills	Costs a lot to install
	Does not produce much electricity when there is considerable cloud cover, during the winter months or at night

Tidal

The UK currently only generates a small amount of energy from tidal power, but it is estimated that the UK could potentially harness around a fifth of its electricity demand in this way. Tidal energy relies on the gravitational pull of the Moon, which causes the change in water levels known as tides.

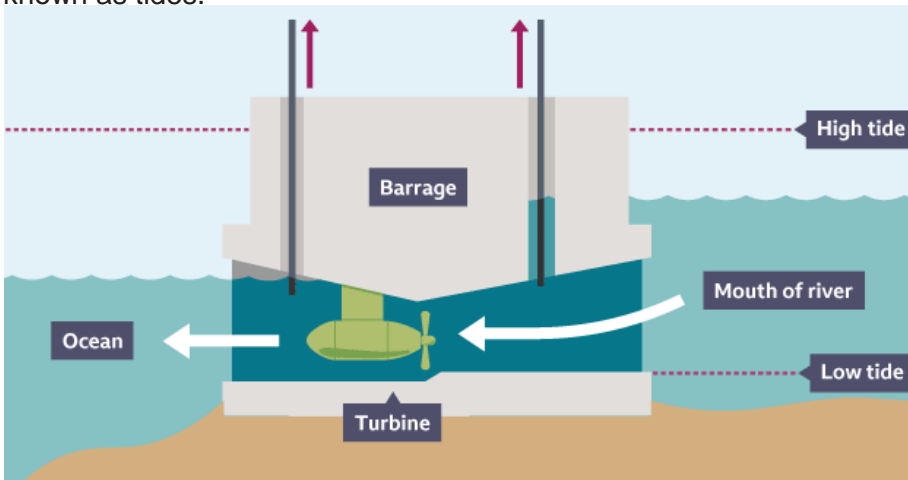

Advantages of tidal	Disadvantages of tidal
Clean, renewable energy source	Construction of tidal barrages is expensive
Tidal power plants will last for a long time	Environmental impact of tidal barrages is unknown
Could produce a fifth of the UK's needs as it is an island surrounded by the sea	

Hydroelectricity

Hydroelectric schemes use a **dam** to block a valley or a major river, often creating a **reservoir** behind the dam.

Once the water has built up behind the dam, it is directed and released by **valves** through turbines. The turbines turn generators to produce electricity.

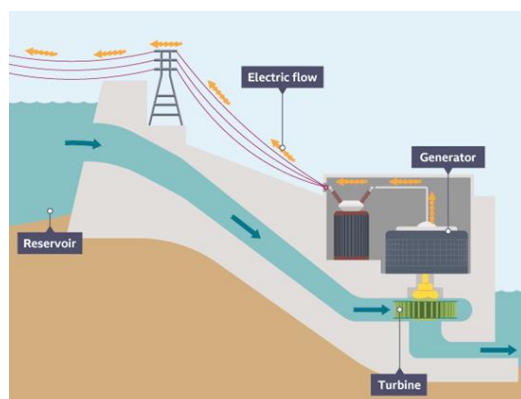

Advantages of hydroelectricity	Disadvantages of hydroelectricity
Clean, renewable energy source	Construction of dams is expensive
Valves can be opened very quickly to produce energy at peak times	Objections from people in the surrounding environment
No pollution when running it	Affects the wildlife by flooding the valley

Biomass

Biomass energy involves growing plants or using animal materials, not for consumption but so that they can be burned to produce heat. Plants such as rapeseed or willow are specifically grown as biomass crops so that they can be burned in a furnace.

Advantages of biomass	Disadvantages of biomass
Clean, renewable energy source	Creates atmospheric pollution when burned
Carbon dioxide is released in the process and can be reused by plants	Land used for energy crops may be needed for other purposes such as agriculture
Replacement plants can be grown very quickly to ensure a good supply	

Powering systems

Batteries

The two main types of batteries that are commonly used are 'single-use' and 'rechargeable'. The single-use batteries, sometimes referred to as primary types, are commonly **alkaline** batteries, and these are readily available in supermarkets and shops. Batteries supply **direct current (dc)**. Incorrect disposal of both rechargeable and single use batteries can lead to chemicals leaking into the environment eg water and soil.

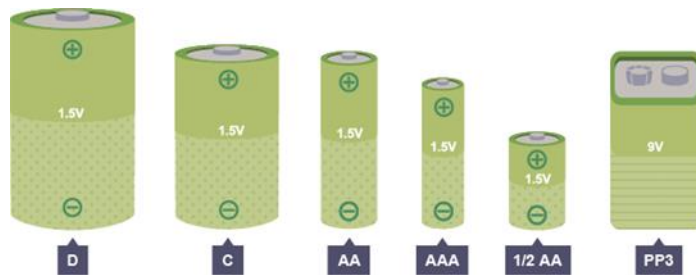

Type of battery	Advantages	Disadvantages
Single-use	Convenient source of power	Expensive in the long term
Rechargeable	Can be recharged and are more economical in the long term (although more initially expensive to purchase than single-use batteries)	They can only be recharged a number of times before they lose battery life

All batteries are available in a range of sizes and shapes - tiny batteries known as **button-cell batteries** power calculators and hearing aids, while very large batteries power cars and trucks.

Button-cell batteries in a calculator



Common forms of batteries used in homes are AA and AAA, and both typically produce around 1.5 volts (V) per battery. A larger PP3 battery, often used for smoke alarms and medical equipment, typically produces 9 volts (V) per battery.

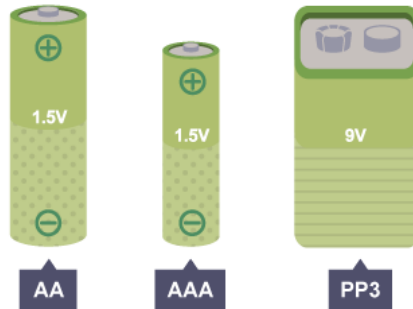

Once a battery runs out it has to be replaced unless it is rechargeable, in which case it is connected to a mains power source to be recharged.



Batteries can be **recycled** to prevent them ending up in **landfill sites**. Batteries contain harmful chemicals and metals that are bad for the environment if disposed of incorrectly; these elements can contaminate the ground or poison the wildlife that may eat them.

Mains electricity

Mains electricity is supplied by the **National Grid** through the use of local power distribution stations. Mains electricity is supplied to homes, offices, factories and public buildings, including places like hospitals and fire stations. Unlike batteries, which deliver direct current (dc), mains power delivers **alternating current (ac)**.

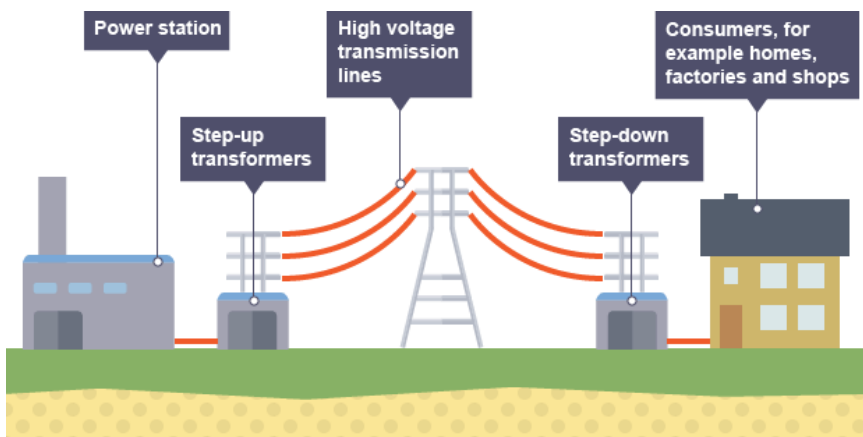

Electricity used in homes, eg through power sockets, enters at 230 volts (V) and is instantly available.

Choosing energy sources

There are many considerations for a designer when selecting energy sources for use in a product, including:

- portability of the power source
- environmental impact
- power output
- circuit/systems connections
- cost

Portability of power source

Technology advances mean many electronics products, from tablets to hearing aids, do not require a main power supply to operate them. Portable devices are powered by a battery that can be recharged as required.

Environmental impact

The impact from the production of energy can be classified as **active** or **passive** as no method of energy production is entirely clean.

Burning of fossil fuels to produce energy has an active impact on the environment as it releases **greenhouse gases** and other pollutants into the environment. The building of wind turbines to produce energy has a passive impact on the environment; it doesn't produce any greenhouse gases but can produce noise pollution, which is an issue in built-up environments.

Wind turbines generating electricity



Power output

A designer will need to consider how reliable they need their power supplies to be, whilst also considering the impact that producing power has on the environment. The power output from power generators will vary depending on the source of the power. **Renewable** power plants produce an irregular output of power. For example, wind turbines rely on there being a constant supply of wind, which is dependent on weather conditions. Therefore weather conditions will dictate the amount of power outputted by a wind turbine.

Circuit/system connections

Electronic products will have a **circuit** within them; the circuit will require connecting to a power source. This power source will impact on the selection of how it is connected to the circuit.

Cost

The selection of a power source will play a role in the running cost of a product. A designer must make the correct choice regarding power, as an expensive running cost could have an impact on product sales.

Example

A designer is thinking of producing a kettle rated at 2,000 watts (W), which takes 150 seconds to boil water. Calculate the consumption of electricity in watts.

Consumption = watts (W) × hours of use

Convert 150 seconds into hours:

$$150 \div 60 = 2.5 \text{ minutes}$$

$$2.5 \div 60 = 0.042 \text{ hours}$$

Multiply this by the wattage:

$$0.042 \times 2,000 = \mathbf{84 \text{ watts (W)}}$$

Question 1

A microwave is rated at 750 watts (W) and is used for 2 minutes. How much power does it consume

Developments in modern materials

Developments in science and engineering lead to changes in materials technology. There are a range of modern materials with impressive properties, as well as traditional ones such as wood or metal.

What is a modern material?

Modern materials are not naturally occurring, and have to have been developed. Modern materials are used alongside traditional materials such as paper, wood, stone and metals.

A modern material is a material that has been engineered to have improved properties.

What is a smart material?

While smart materials are modern materials, modern materials are not necessarily smart.

To be classed as a 'smart material' they need to exhibit a physical change in response to some external stimuli.

In other words, they change when you do something to them, and when you remove what is causing that change they return to their original form.

Modern and smart materials are constantly being engineered, so it's good to try to keep up to date with the latest developments. They can often be incorporated into new consumer products without people noticing.

Shape-memory alloys (SMA) are metal **alloys** that can remember their shape when heated.

These alloys have been utilised on spectacle frames that spring back to shape if they are squashed.

Nickel titanium (**nitinol**) is a type of SMA, and it contracts when heated, whereas most metals expand. When braces are made from nitinol, they heat up in the mouth and 'pull' on the teeth, so they move with the nitinol.

Nanomaterials are tiny particles of 1 to 100 nanometres (nm) that can be used in thin films or coatings such as the **oleophobic** coatings on **smartphone** screens that repel greasy fingerprints, or **hydrophobic** materials that repel water.

Hydrophobic material



Photochromic pigments change their properties when exposed to **ultraviolet (UV) light**. A well-known example would be glasses where the lenses are clear when worn inside a building, but become more like sunglasses when exposed to bright sunlight outside. The same technology has been used in windows to prevent rooms from getting too hot in warm weather.

Reactive glass is a material that changes from **transparent** to **opaque** by passing current through an **electrochromic** material built into the glass. Common applications include privacy glass and auto-dimming rear view mirrors in cars that help prevent the driver being dazzled by bright lights.

Reactive glass used in an auto-dimming rear view mirror in a car



A **piezoelectric** material can generate electricity when pressure is applied. Common applications include keypad sensors, alarm systems and microphones. Quartz crystals are an example of a piezoelectric material.

Conductive inks are made from a precious metal, such as silver, which can make them expensive. They are available in pen form and can be used to draw circuit diagrams. When the ink dries a current is able to flow through the material.

Temperature-responsive polymers respond to temperature change by displaying a change in property. This is a new material and is still under research but current applications are in the medical field for the controlled delivery of medication.

Composite materials

Composite materials are made up of different materials which are combined to improve their **properties**. They can be a combination of **natural** and **synthetic** materials but fall into three main categories:

- fibre-based composites
- particle-based composites
- sheet-based composites

Fibre-based composites

Fibre-based composites are reinforced with fibres. By mixing **resin** or concrete with fibres of glass or carbon we get the ability to mould complex shapes, but reinforcing them with the fibres makes them very strong.

Fibre-based composite	Materials	Uses
Glass-reinforced plastic (GRP)	Glass fibres and resin	Boats, instrument cases
Carbon-reinforced plastic (CRP)	Carbon fibre and resin	Formula 1 car bodies, crash helmets, sports equipment
Glass-reinforced concrete (GRC)	Glass fibre and concrete	Street furniture, urban features

Carbon-reinforced plastic (CRP) in automobile parts



Particle-based composites

Particle-based composites are made with small particles of material. By mixing smaller particles of sand with larger particles of cement and **aggregate**, such as stones, we get a very strong and **dense** material suitable for building large structures.

Particle-based composite	Materials	Uses
Concrete	Cement, sand and aggregate	Buildings, street furniture
Cermet	Ceramic (cer) and metal (met)	Electronic components that need to operate under very hot temperatures

Concrete used in construction



Sheet-based composites

Sheet-based composites are often available in large sheets. By mixing wood fibres or thin slices of wood **veneers** with resin it is possible to form large and stable sheets for furniture panels and interior construction.

heet-based composite	Materials	Uses
Medium-density fibreboard (MDF)	Wood pulp and resin	Furniture and interior cladding
Plywood	Wood veneers and resin	Furniture and construction
Chipboard	Wood chip and resin	Furniture panels and construction

Plywood boards



Like all modern materials, composites are engineered to improve their properties. There are many more combinations of materials that are designed to meet a particular need or purpose. For example, wood has been reinforced with strips of carbon to make a wooden bicycle frame.

Often the original material has a useful feature, the ability to be formed or a certain appearance, but lacks strength or **durability**. In this case different material combinations can solve the problem and new composites are being developed all the time.

Robotic materials are able to sense changes in surroundings and morph, changing shape. Robotic materials are used in state of the art military aircrafts wings, which change shape to improve aerodynamics and make them more efficient.

Technical textiles

Textiles have come a long way since the early days of cotton and silk, and today's modern textiles have some very advanced and useful **properties**.

A major advance in textiles technology was the invention of polyamide, more commonly known as **nylon**. This **synthetic** material can be pulled into very thin strands when heated and **spun** just like natural textiles, and is now used extensively as a fabric in clothing.

Modern textiles can be engineered to have numerous properties, such as additional strength or resistance to fire, water and even dirt.

Agrotextiles are extensively used in farming to increase the production of agricultural products. These materials provide protection from the sun and insects and reduce the reliance on pesticides. Some examples of agrotextiles are wool, jute, nylon, polyester and polypropylene.

Agrotextiles used as a weed suppressor



Construction textiles are materials used in the construction industry for function and appearance. These materials are strong, light, designed to be resistant to chemicals and sunlight and perform a range of functions, including:

- thermal insulation
- sound insulation
- water resistance
- reinforcement

Geotextiles are used to improve drainage where soil and rock materials may cause water to sit on the surface. They can also be used for stabilising and reinforcing where the ground is unstable and may collapse, eg coastal areas. Primarily, geotextiles are used in civil engineering projects, eg road embankments and railroads.

Geotextiles are used to prepare the ground before new roads are laid



Domestic textiles are used in homes and offices, with examples ranging from flooring to antibacterial cleaning wipes. These materials may have been designed for other uses but are now commonly use for domestic applications.

Environmentally-friendly textiles are made from recycled materials or **natural fibres** such as cotton, wool and bamboo. They can be expensive, but they can also be mould and pest resistant.

Bamboo fibre blankets



Sports textiles are used in most sports clothing and footwear. The materials are developed to combine material functions to meet a specific need. For example, the material for a football kit is developed to be breathable, lightweight, draw moisture away and control bacteria.

Electronic systems

Electronic systems can be understood using a systems block approach of input, process and output. This is vital in designing systems to understand how devices are programmed and how they operate.

Input

Input devices allow systems to understand changes in the environment around them. For example, a **sensor** like a **light-dependent resistor (LDR)** that senses light levels for street lamps that know when it is dark, or **thermistors** that detect when it is too hot or cold in a room.

Purpose of input devices

Input devices take a signal from the physical or 'real world' and turn it into an electronic signal that a process device, such as a microcontroller, can understand and act upon.

- examples of real world signals include light level, temperature and pressure
- examples of electronic signals include **voltage** and **current**

Sensors

Sensors can be used to detect changes in light level, temperature and pressure. They are used in a wide range of products, from night lights to security alarms and central heating systems.

Types of sensors

A light dependent resistor (LDR) is a special type of resistor whose **resistance** changes with the light level. As the light gets brighter, its resistance decreases. It can therefore be used as a simple light sensor.

A thermistor works in a similar way except it responds to changing temperature levels. Usually its resistance decreases as the temperature increases but some thermistors can work in the opposite way where resistance increases as temperature increases. An example of a use for a thermistor is in a heating system. It can be used to check the temperature in a room and trigger the turning on of a heater if it is too cold.

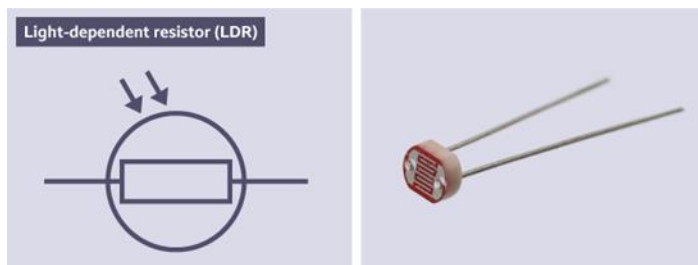

Question 2

Name a suitable input device for a greenhouse cooling system.

Microcontrollers as process devices

Microcontrollers provide **functionality** and give intelligence to products and systems. From mobile phones to washing machines, many everyday products are controlled by these devices.

Purpose of process devices

Process devices take the signal from the **input** stage of a system and act on it by changing it in some way. For example, introducing a time delay, counting the number of times something happens or making decisions. **Programmable components**, such as microcontrollers, are often used for this purpose.

Microcontrollers

A microcontroller is an example of a SBC (single board computer) and is manufactured as an integrated circuit (IC). It can be programmed to perform different processing functions.

Microcontrollers come in different sizes with varying numbers of **pins** for the connection of input and **output devices** - for example, 8 pin, 14 pin and 18 pin. A programmable interface controller (PIC) is an example of a microcontroller that is widely used.

Microcontrollers in different sizes with varying numbers of pins



Advantages and disadvantages of using microcontrollers

Advantages

- The size of a circuit can be significantly reduced. This is because programming replaces physical components.
- They can be reprogrammed many times. This allows changes to be made without replacing actual components.
- They have pins for connecting several input and output devices, adding to flexibility.

Disadvantages

- They often cost more than traditional integrated circuits. They are therefore not always the best option for simple systems.
- Programming software and hardware is required. This can be expensive to buy.
- The language of the system must be learned and this adds to training costs.

Programming microcontrollers

In order for **microcontrollers** to work correctly they must be **programmed**. This can be achieved using a wide range of **software**, **hardware** and different **programming languages**.

Programming methods

Microcontrollers can be programmed using a range of different methods. These include:

- text-based programming languages**, such as BASIC, C++, and Python
- block-based programming editors**
- flowchart software**

Each have their own advantages and disadvantages.

Block-based editors are simple to use but can be limiting if complex programs need to be written. **Text-based languages** add more flexibility but are harder to understand and use. **Flowcharts** are simple and easy to read but there can be bugs in the system

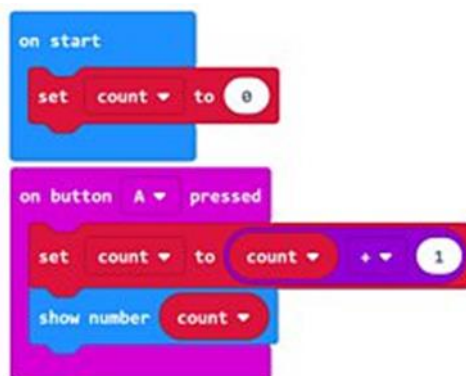

Example of block-based editing

Example of a flowchart program

The program below acts as a simple timer. When an input **pin** detects a high (on) signal, it turns an output on for twenty seconds. Software such as PICAXE Editor, GENIE and Yenka can be used for writing flowchart programs.

Flowchart programme
of a simple timer

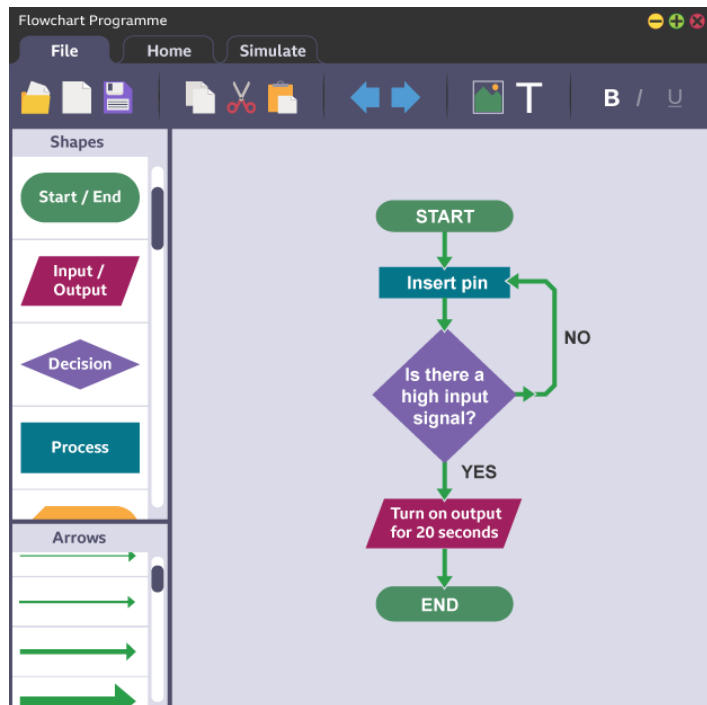

Downloading a program

Once written and tested, the program must be downloaded onto the microcontroller. Many systems support '**in-circuit**' programming. This means the microcontroller does not have to be removed from the circuit to be programmed. For some systems, the chip may have to be taken from the circuit and placed in a special **downloader**. A **serial** or USB cable is commonly used to download the program.

Control devices

Purpose of control devices

A **control device** processes the input. When processed, this will cause an output to turn on. Sensors gather measurable data, such as a change in light or temperature, which is collected by a **processor** that is programmed with code on how to respond.

Switches

Switches allow **current** to flow through them when the **contacts** inside are joined together. They are usually named after how they work. For example, a **push-to-make switch** allows current to flow (or a signal to be passed on for processing) when pressed, therefore 'making' the circuit. A **push-to-break switch** does the reverse and 'breaks' the circuit.

Other examples of switches include:

- reed (magnetic) switch
- rocker switch
- toggle switch
- tilt switch

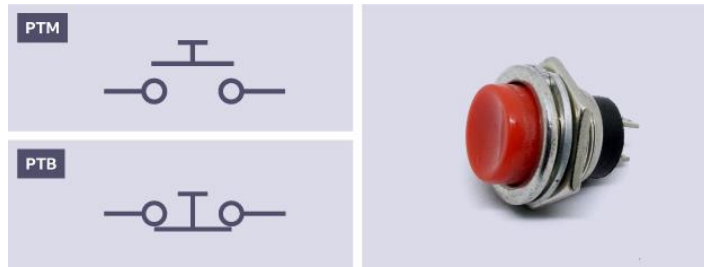

Push-to-make (PTM) and push-to-break (PTB) switch

Examples of uses for each kind of switch may include:

Type of switch	Uses
PTM/PTB switch	Console controller buttons, eg fire or jump
Reed (magnetic) switch	Window sensors on alarms, eg window opens and switch contacts open
Toggle switch	Power switches
Rocker switch	Light switches
Tilt switch	To detect if something is no longer level

The function of a toggle switch and rocker switch can be exactly the same - it is the shape of the case that determines what the switch is called.

Transistors

A **transistor** is a **semi-conductor** that amplifies a signal from a sensor - it is like a small electronic switch. Transistors have three legs, **base**, **collector** and **emitter**.

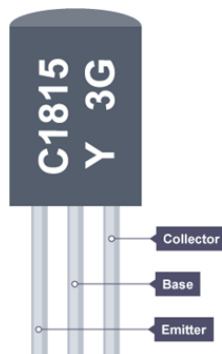

When a small **voltage** at the base connection is detected, the transistor is switched on and a large **current** can flow in through the collector and out through the emitter

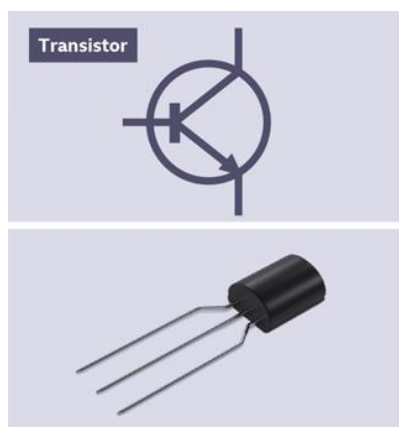

Advantages

- inexpensive way of improving the sensitivity of a circuit
- can be made a very small size to reduce the size of a circuit

Disadvantages

- sensitive to heat and can be damaged during soldering#

Resistor

A resistor allows the resistance in a circuit to be changed by limiting the flow of electric current. Resistors are used in circuits to protect delicate components by controlling the flow of electricity. For example, if too much **current** flows through a **light-emitting diode (LED)** it will be permanently damaged. This use of a resistor protects the LED by limiting the flow of current through it.

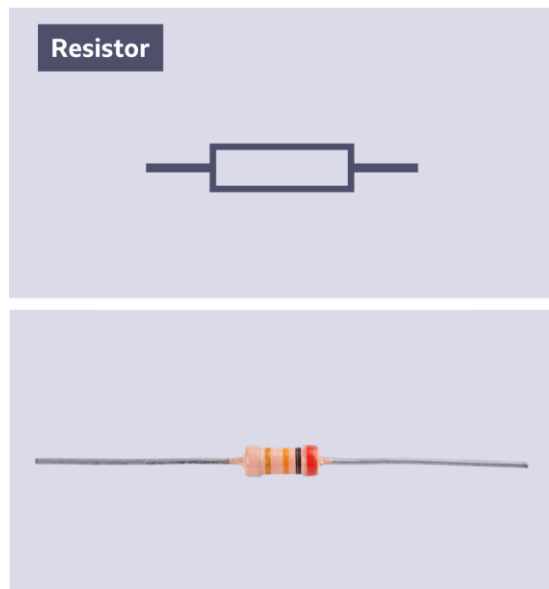

Advantages

- resistors are available in a range of values - 0 Ohms (Ω) resistors can be used in circuits instead of **flying leads**
- used to protect sensitive components by limiting the flow of current through it

Disadvantages

- if the wrong value resistor is installed in a circuit the circuit will not function correctly or may not function at all

Question 3

Which switch might be used to alert someone a boat may capsize?

Outputs

Output devices allow a system to present information back into the 'real' world. They take the signal from the **process device** of a system and turn it back into physical or 'real world' signal, such as light or sound. Examples can be seen everywhere, from car indicators to doorbell buzzers or information displays.

Light outputs

Light can be produced in different ways; a **light-emitting diode (LED)** is the most common component used for producing light. LEDs are made from two types of **semi-conductor** material that emit light when current flows through it:

- LEDs only work in one direction
- the long leg is the positive (+) side known as the **anode** and the short leg is the negative (-) side known as the **cathode**

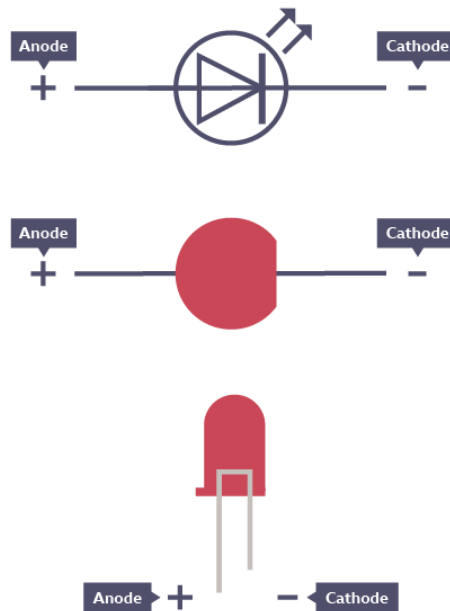

Advantages

- LEDs come in a wide range of colours and sizes
- they are more energy efficient than other bulbs and have a longer life span

Disadvantages

- a resistor is placed in series with a LED to protect the LED from a high supply voltage - if the wrong value resistor is used, the LED may burn out or not light up at all
- the light from an LED is not always visible at certain angles

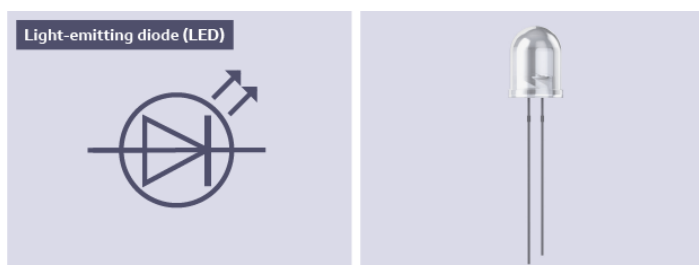

Sound outputs

Sound can be produced using **buzzers**.

Buzzers

- buzzers have an **oscillator** inside a plastic case
- when current flows through them they produce a buzzing sound, often around 400 Hertz (Hz) in **frequency** depending on the type of buzzer used
- examples of their use include in doorbells and alarms

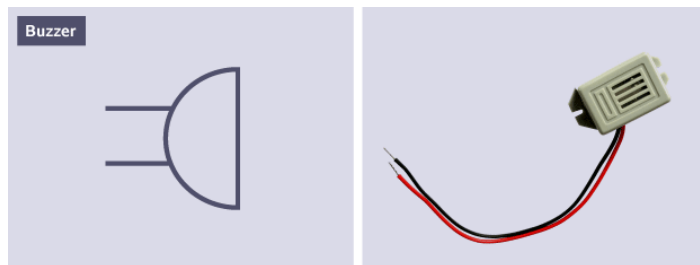

Buzzer - Used to generate a warning sound

Mechanical devices

Mechanical devices can change one form of force to another. All moving parts work on some sort of mechanism

Types of movements

Mechanical devices all have an **input** motion, which transforms into force to make an **output** motion. The four types of motion are:

- Linear
- Rotary
- Reciprocating
- Oscillating

Linear motion moves something in a straight line, eg a train moving down a track:

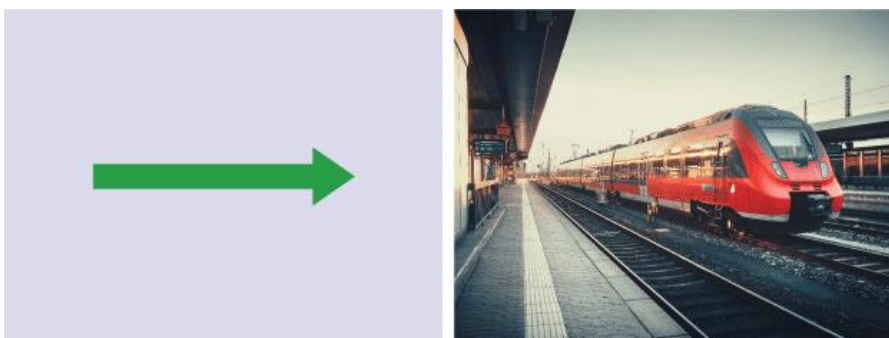

Rotary motion is where something moves around an axis or pivot point, eg a wheel:

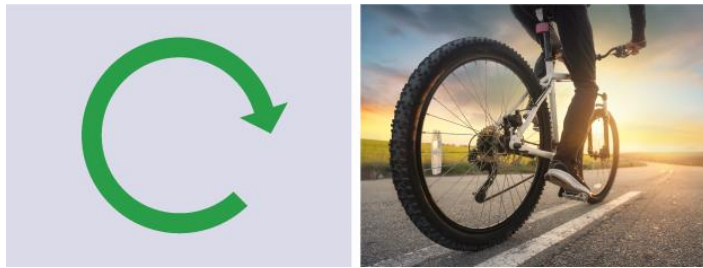

Reciprocating motion has a repeated up and down motion or back and forth motion, eg a piston or pump:



Oscillating motion has a curved backwards and forwards movement that swings on an axis or pivot point, eg a swing or a clock pendulum:

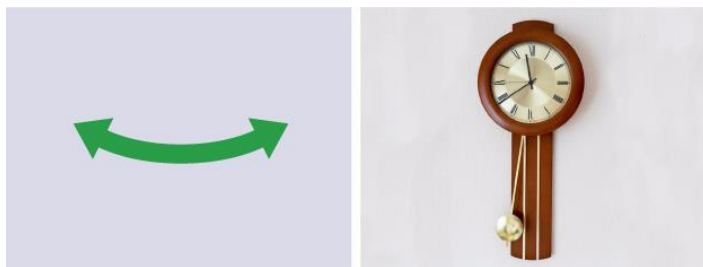

Levers

Levers use **mechanical advantage** to make lifting or applying pressure easier. All levers are made of a bar and a **pivot**, called a **fulcrum**. Levers have three main parts:

- **effort** - the amount of force applied by the user, also referred to as the **input**
- **fulcrum** - where the lever pivots
- **load** - the weight that needs to be moved, also referred to as the **output**

Mechanical advantage is the amount of help you get using a machine in comparison to doing something with just human effort, and it is created by levers.

It is measured by dividing the **load** by the **effort** applied to moving it, both measured in Newtons (N) - this could also be described as the **output** (load) divided by the **input** (effort):

$$\text{mechanical advantage} = \text{load (N)} \div \text{effort (N)}$$

Example

A person lifting a load of 200 N but only using 100 N of effort:

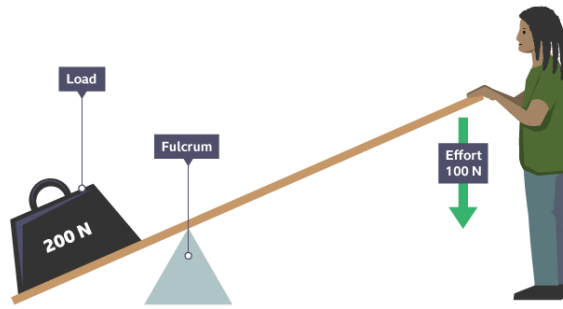

Therefore, the mechanical advantage = $200 \div 100 = 2$.

This can also be written as 2:1. The person is able to lift twice the load using 100 N of effort.

The mechanical advantage can also be calculated theoretically by measuring the distance between the load and pivot and the effort and pivot.

In the picture below the distance between the load and fulcrum is 2 m. The distance between the effort and fulcrum is 6 m.

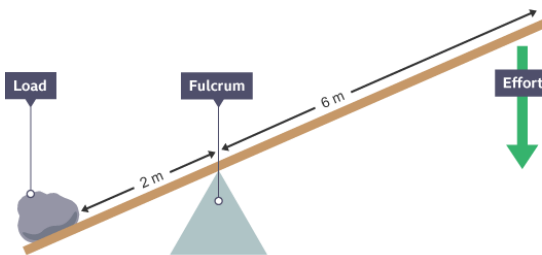

Therefore, the mechanical advantage = $6 \div 2 = 3$ or **3:1**

The person will find this load three times easier to lift.

In both examples we were able to calculate the mechanical advantage. It is possible to calculate any part of the formula as long as we have two pieces of information from the formula:

- mechanical advantage = load \div effort
- load = mechanical advantage \times effort
- effort = load \div mechanical advantage

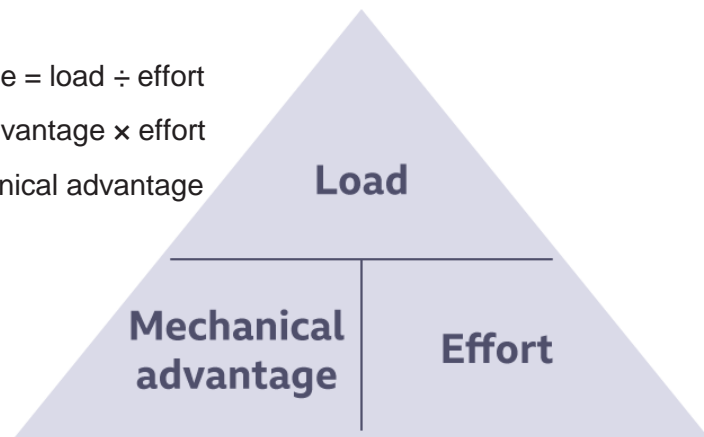

Question 4

A person is using a lever to lift a rock with a 50 N load. The mechanical advantage is 5:1. How much **effort** is the person having to give?

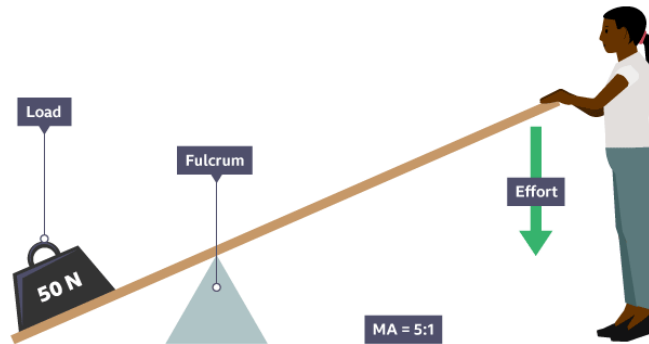

Classes of lever

There are three different types of levers. They are chosen for their ability to produce the most mechanical advantage for a particular task. These classes of lever arrange the effort, fulcrum and load in a different order:

First order	Effort	Fulcrum	Load
Second order	Effort	Load	Fulcrum
Third order	Fulcrum	Effort	Load

First order levers

First order levers (Class 1) place the fulcrum between the effort and the load. An example would be a seesaw, which places the fulcrum in the centre and allows equally weighted children to lift each other up.

If the load is closer to the fulcrum it becomes easier to lift. When the fulcrum is in the centre, like a seesaw, the effort and the load have to be equal to balance them. If a person is slightly heavier at one end or leans back, moving the weight, one end of the seesaw moves down.

When a lever is balanced it has equilibrium - the load is balanced on either side

A crowbar is an example of a first order lever that puts the load closer to the fulcrum - this gives it more power to move a load. When the fulcrum is moved nearer the load it takes less effort to move it.

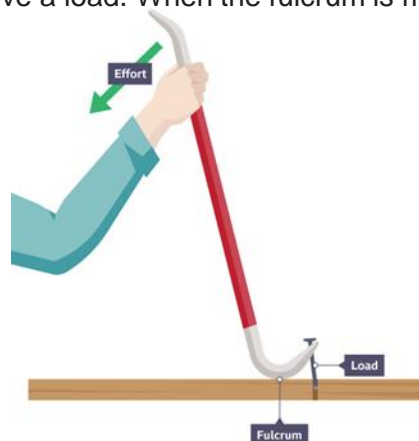

Second order levers

Second order levers (Class 2) place the fulcrum at one end of the lever and the effort at the other, with the load in the centre. The closer together the fulcrum and load are, the easier it is to lift the load. Examples include wheelbarrows, nutcrackers and some bottle openers.

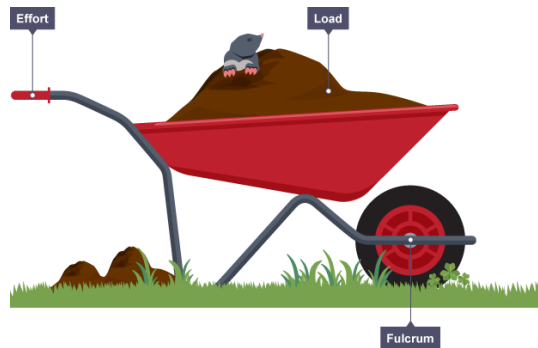

Third order levers

Third order levers (Class 3) place the effort between the fulcrum and the load. If the effort and the fulcrum are further apart, it becomes easier to lift. A third order lever does not have the mechanical advantage of first order levers or second order levers so are less common.

They are generally used for moving small or delicate items. Examples include tweezers or fishing rods.

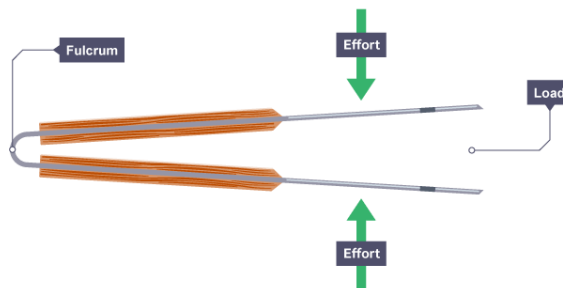

Question 5

The blade on a pair of scissors is an example of which type of lever?

Linkages

Levers can be joined together to form **linkages**. Simple linkages change the direction of motion and the amount of force.

Reverse motion

Reverse motion linkages change the direction of input so that the output goes the opposite way. A fixed **pivot** forces the change in direction. These are often used on foldable clothes horses.

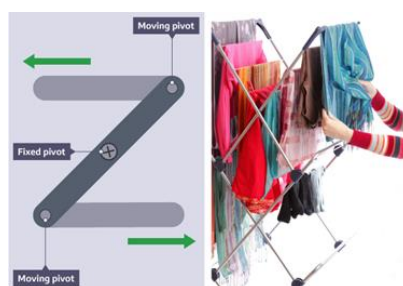

Parallel or push/pull

Parallel motion or push/pull linkages use two fixed pivots to make the input and output travel in the same direction, through a link arm. Each fixed pivot has a moving pivot on either side, allowing the movement and power to go backwards and forwards. Changing the placing of the fixed pivots changes the amount of force exerted, while keeping the direction the same. For example, a toolbox with drawers opens up effectively using parallel motion linkages.

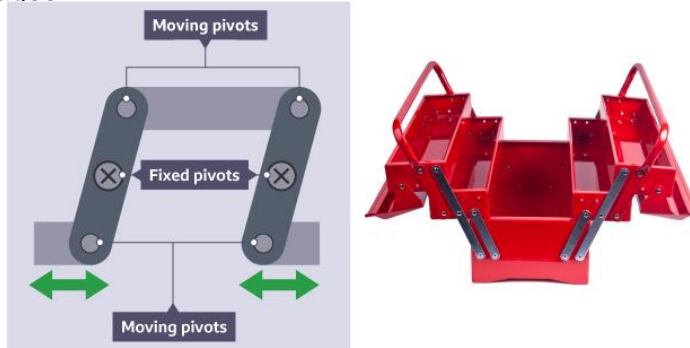

Bell crank

Bell crank linkages change the direction of force through 90° . The amount of output force can be changed by moving the fixed pivot. When used in bicycle brakes, the rider can pull the brakes from the handlebars, which changes direction through the bell crank to make the brake pads touch the wheels.

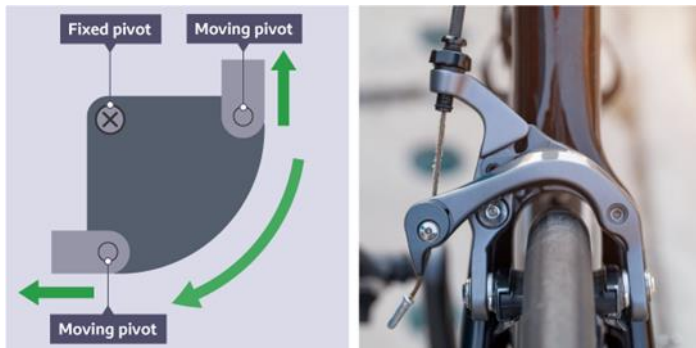

Crank and slider

Crank and slider linkages change **rotary motion** from the crank into a **reciprocating motion** of the slider. The **crank** and slider are connected through a connecting rod which helps convert the motion. There are arrangements in which a crank and slider can be used. The crank arm can be used as the driver in a car engine piston, the ignition of petrol by the spark plugs pushes the slider up, moving the connecting rod and turning the crank. Alternatively, the slider can be used as the driver in a steam engine where the wheels turn because of the pressure that moves the slider.

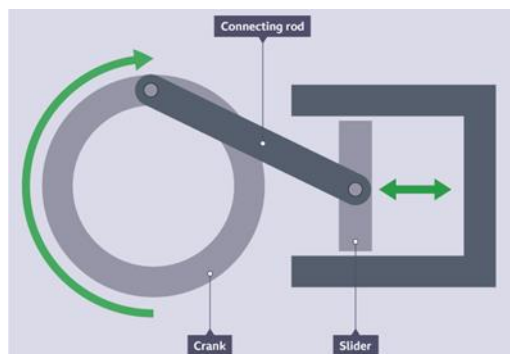

Treadle

Treadle linkages use a rotary input to turn a crank on a fixed pivot. A connecting rod joins two moving pivots to another fixed pivot. This is how a pair of windscreen wipers works on a car, moving backwards and forwards together.

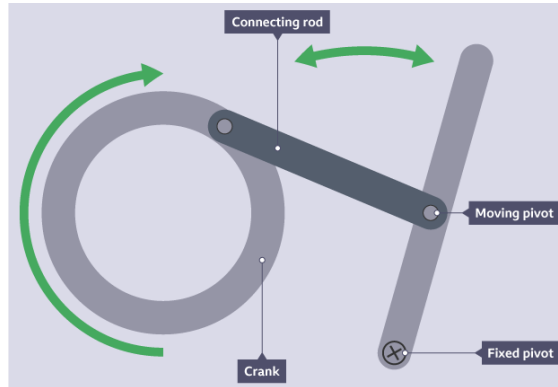

Angles in linkages

It is important when using levers to understand the angles in place for each arrangement. This way a designer can design appropriately for users' needs.

A reverse motion linkage replicates a 'Z' angle. Z angles feature two internal angles, which will both be the same as long the input and output linkages remain parallel.

In the image below, the top internal angle is 30° , and therefore the alternate internal angle at the bottom is also 30° :

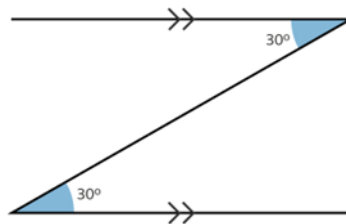

Where two lines intersect, the **opposite angles are equal**, and where two angles sit on a horizontal line the total angle together is 180

$$X + Y = 180$$

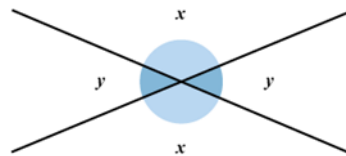

Also, corresponding angles are the same size in this 'F' arrangement

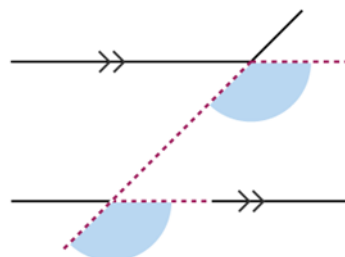

Example

From all of this, the angles A, B and C can be calculated for the parallel linkage below:

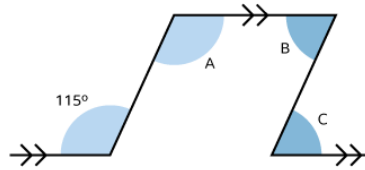

A = 115° as it matches 115° on the Z angle

A and B both sit on a horizontal line, so $115^\circ + B = 180^\circ$

$180^\circ - 115^\circ = 65^\circ$, so angle B = 65°

B and C match on a Z angle, so B and C are both 65° .

Question 6

Calculate angles A, B and C in the parallel linkage below:

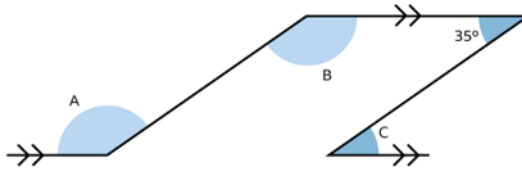

Cams and followers

A **cam mechanism** has two main parts:

- a **cam** - attached to a **crankshaft**, which rotates
- a **follower** - touches the cam and follows the shape, moving up and down

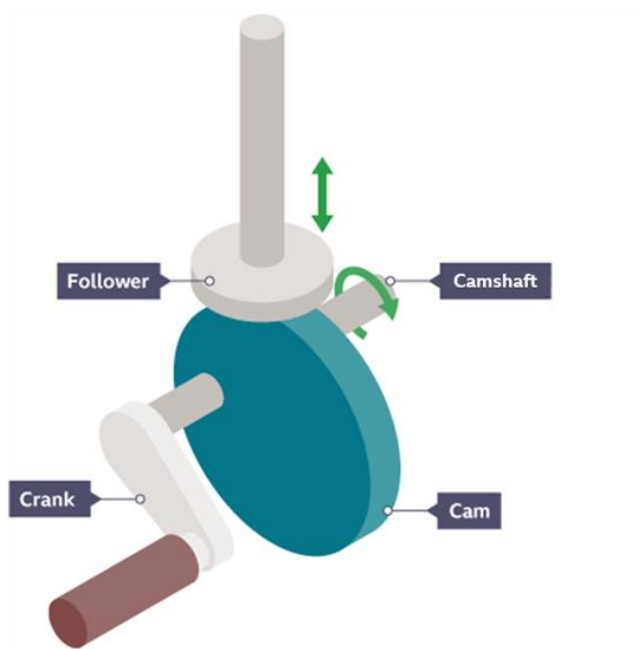

Cams

Cams can be produced in any shape, but the most common shapes are:

Circular

Circular cams use an off-centre pivot to cause the follower to move up and down. The follower will rise and fall by a reasonably large amount. These can be seen in pistons, for example on steam engines.

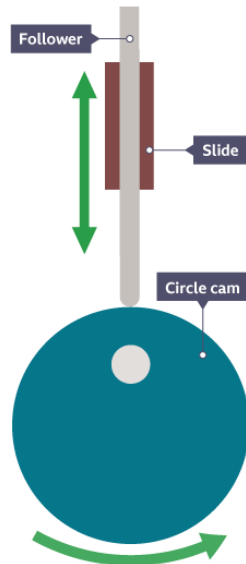

Pear

Pear cams are called this as they have the shape of a pear. It remains stationary for half a turn then gently rises and falls. These are used to make carousel horses rise and fall.

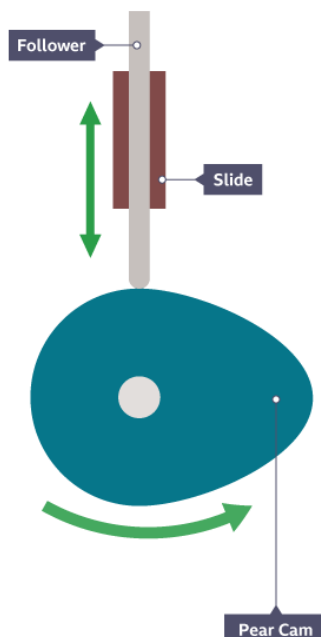

Snail or drop

Snail or drop cams have the appearance of a snail shell. It causes the follower to remain stationary for half a turn before gently rising and suddenly falling. They can only work by rotating in one direction. Used on production lines to make regular holes or cuts in an item as it rotates and drops at regular intervals.

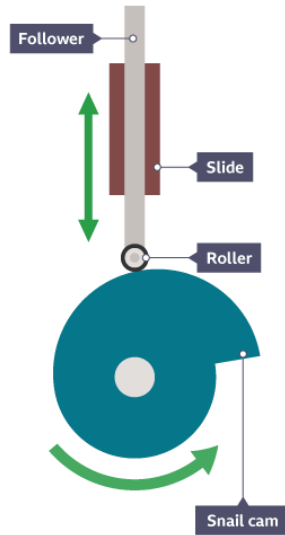

Heart-shaped or constant velocity

Heart-shaped cam or constant velocity cams have a shape similar to a heart. The follower rises and falls steadily with uniform velocity. There is no stationary period.

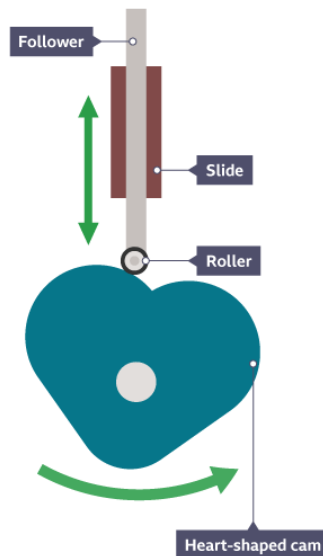

Followers

The purpose of a cam is to move a follower up and down. There are three main types of followers:

Flat

Flat followers have a flat bottom that sits on the cam. These cope well under load but aren't very accurate and have a lot of friction.

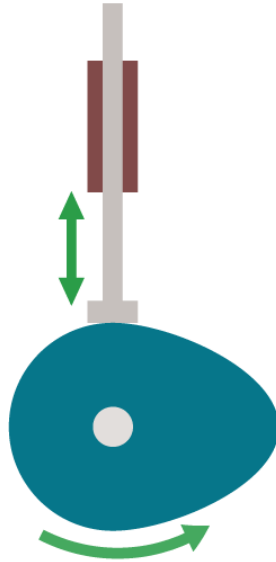

Point or knife

Point or knife followers have a narrow point that sits on the cam. These are very accurate and low friction but are quick to wear away the pointed edge.

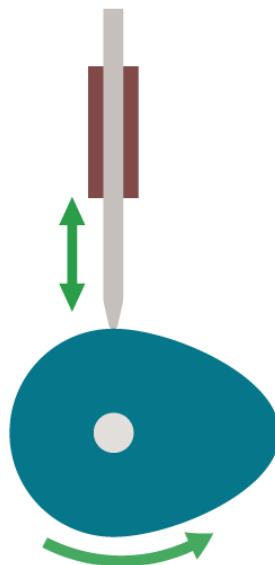

Roller

Roller followers have a roller such as a ball bearing attached to the bottom of the following. These are accurate, low on friction and can withstand load, but are more costly to produce.

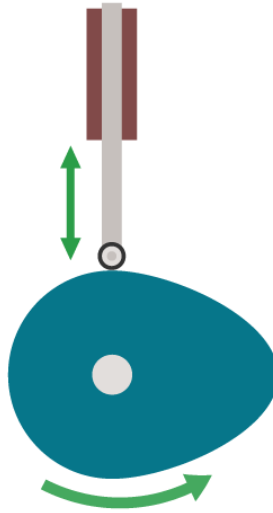

Gear types and trains

Gears are wheels with **teeth** around the outside. When several wheels are interlocked, they can transfer motion from one place to another, eg in some hand whisks or on bikes.



Gears can change the direction or the speed of movement. As there are teeth around the edge of the gears they grip together and so can withstand a greater force, enabling them to move large items such as cars or bicycles.

Gear trains

Gear trains are when two or more gears are joined together. In a simple gear train, the **drive gear** causes the **driven gear** to turn in the opposite direction.

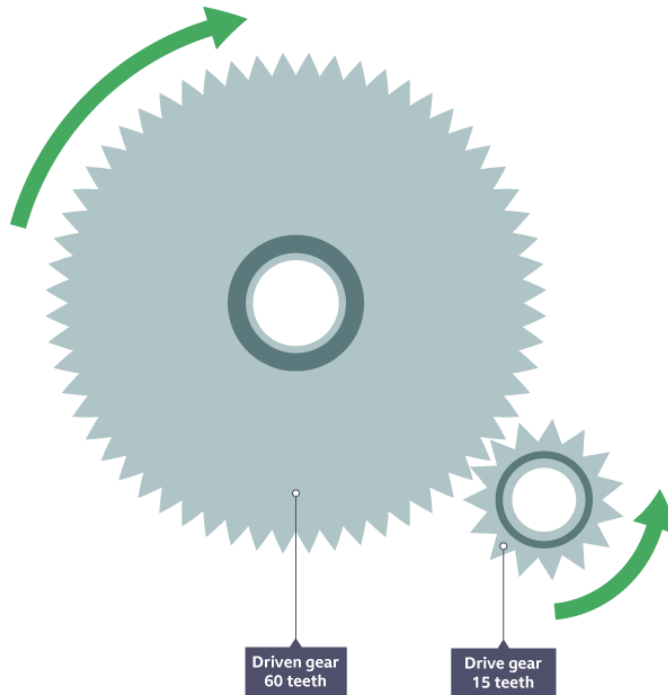

Smaller gears with fewer teeth turn faster than larger gears with more teeth. This difference in speed is called the **gear ratio**.

Gear ratio = number of teeth on driven gear ÷ number of teeth on the drive gear

Example

The driven gear has 60 teeth and the drive gear has 15 teeth.

Gear ratio = $60 \div 15$

= 4

For each rotation of the drive gear, the driven gear would rotate four times.

Gear ratio = 4:1

This is known as **gearing up**. If the driven gear had 15 teeth and the drive gear had 60 teeth, the gear ratio would be 4:1 which is known as **gearing down**.

Question 7

If a cyclist is pedalling with a driven gear of 50 teeth and a drive gear of 25 teeth, what is the gear ratio?

Gear types

If the drive gear and the driven gear are separated by another gear, called the **idler**, they will move in the same direction.

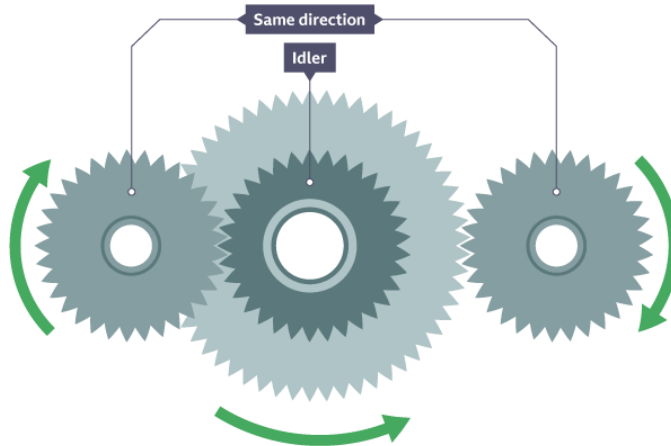

Bevel gears

A **bevel gear** is a special gear that can transfer rotary through 90 degrees. The diagram below shows two gears of the same size - the name given to this arrangement is a mitre-gear.

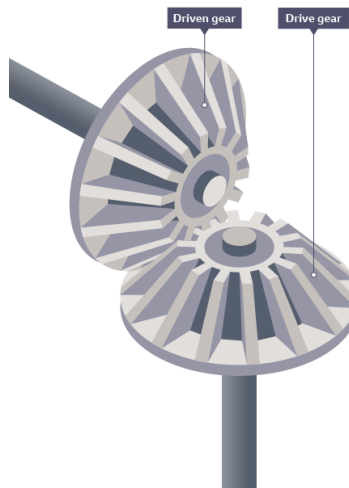

However, the two gears can vary in size to achieve a different gear ratio. An example of this is in a hand drill, where the drive gear is larger than the driven gear.



A hand drill with a mitre-gear arrangement where the drive gear is larger than the driven gear

Rack and pinion

A **rack and pinion** is an arrangement of a gear wheel and a rack which allows the rotary motion to be converted to linear motion. An example this is in a pillar drill, where the table bed is moved up and down.

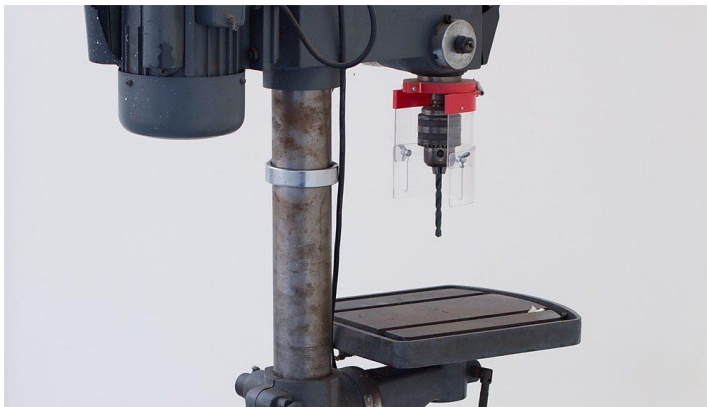
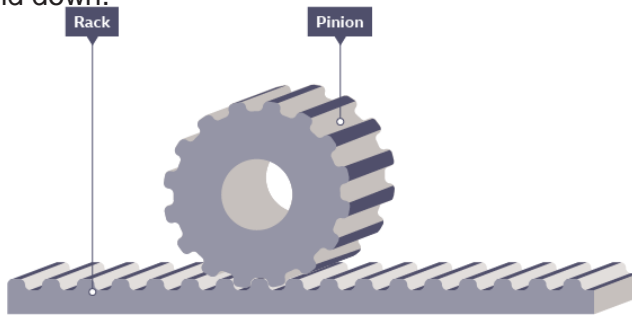

A pillar drill with a rack and pinion arrangement

The speed at which a gear or wheel rotates is measured in revolutions per minute (rpm). Many cars have a rev counter that tells the driver how fast the engine is spinning.



A rev counter from a car

Output speed = input speed ÷ gear ratio

Example

A driver gear rotating at 60 rpm is connected to a gear arrangement with a ratio of 60:20.

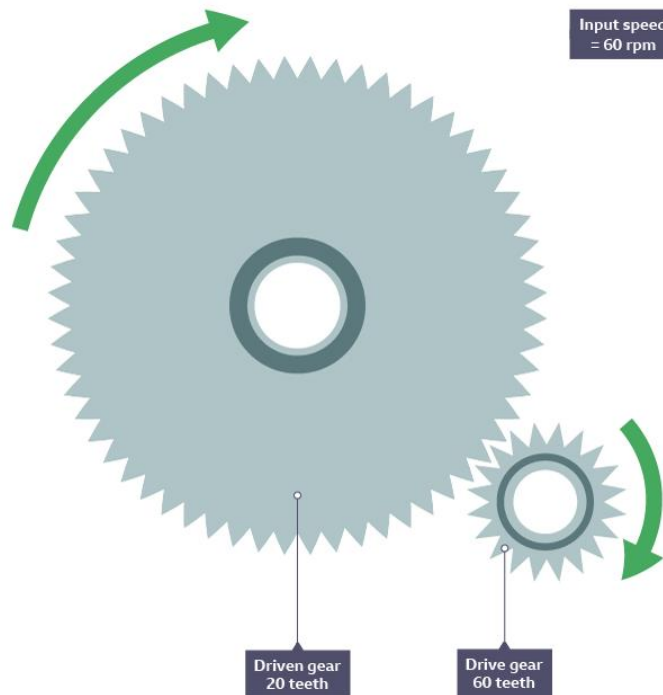

Calculate the output speed.

Gear ratio = number of teeth on driven gear \div number of teeth on the drive gear

$$= 60 \div 20 = 3$$

Output speed = input speed \div gear ratio

$$= 60 \text{ (rpm)} \div 3 = \mathbf{20 \text{ rpm}}$$

In this arrangement the output speed is **three times slower** compared to the input speed.

Question 8

A driver gear rotating at 120 rpm is connected to a gear arrangement with a ratio of 6:12.
Calculate the output speed

Pulleys and belts

Pulleys

Pulleys use **mechanical advantage**, similar to levers, to lift up loads. Pulleys are wheel shaped with a groove that allows a cord to sit inside the groove. They can be used by hand or attached to a motorised **winch** to increase the amount of weight that can be lifted.

Pulleys are a simple and manoeuvrable way to move large objects. They are easy to transport to where they are needed and set up, but they do require somewhere stable to hang.

A single pulley changes the direction of force, making pulling down easier than lifting up. Single pulley systems are demonstrated in cranes, lifting a bucket from a well, raising a flag or adjusting window blinds. Even though there is no actual mechanical advantage with one pulley, it is referred to as having a mechanical advantage of one.

A single fixed pulley has a mechanical advantage of one.

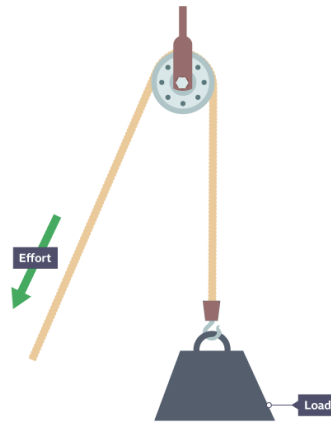

One pulley doesn't make a mechanical advantage, as the same amount of force is needed. However, if additional pulleys are added, a mechanical advantage is created. Using two pulleys together means you need half the force to lift. This is called a **block and tackle**, and is used to lift large, difficult-shaped objects, such as furniture. Adding more wheels to the block and tackle increases the load it can lift.

A block and tackle

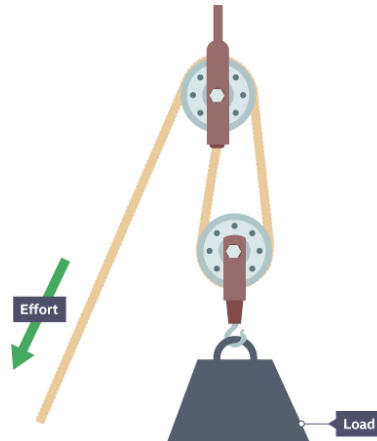

The mechanical advantage is equal to the number of sections of rope pulling up on the object

A movable pulley

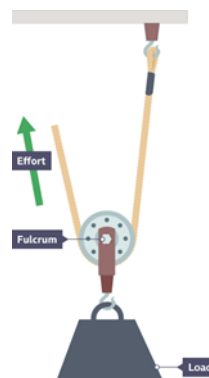

The mechanical advantage of a movable pulley (one where the pulley can move freely along the rope) is two.

Example

The 10 N load below would still require 10 N of force to lift as the extra pulley is not taking any additional strain in weight - the weight is still taken by only one section of rope.

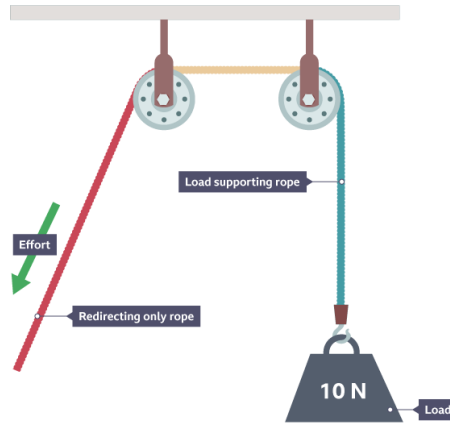

The 10 N load below would require half of the force to lift. There are two sections of rope taking the strain, so 5 N of force would be needed to lift it. The mechanical advantage would be 2.

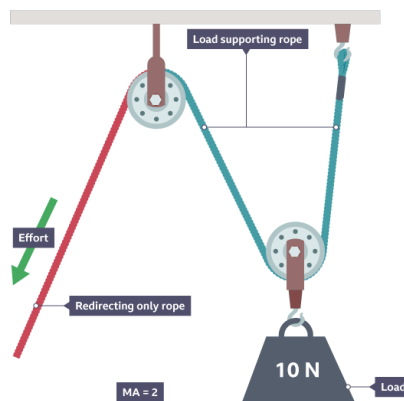

Question 9

The pulley system below features 300 N of load and 3 pulleys

What weight is needed to pull the load?

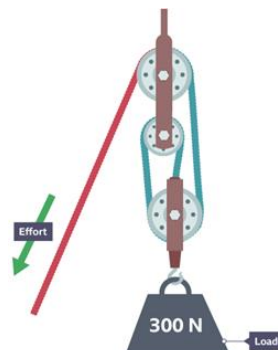

Belts

Belt drives transfer movement from one rotating pulley to another, each held on a **shaft**. Shafts and pulley wheels can be made out of any material, whereas pulley belts are generally made from a soft, flexible material such as rubber. Grooves on the pulleys and belts help them to grip and turn.

Grooves on a pulley and belt help this grip



Winches, treadmills and washing machines are examples of belt-driven **mechanisms**.

Washing machine belt drive



Belts can be attached around different-sized pulleys to drive shafts to change speed. As with gears, the bigger the wheel, the slower the speed. The **velocity ratio** between two pulleys can be calculated.

Velocity ratio = diameter of the driven pulley ÷ diameter of the driver pulley

This can then be used to calculate the output speed:

Output speed = input speed ÷ velocity ratio

Example

A driven pulley has a diameter of 120 mm and a driver pulley has a diameter of 40 mm.

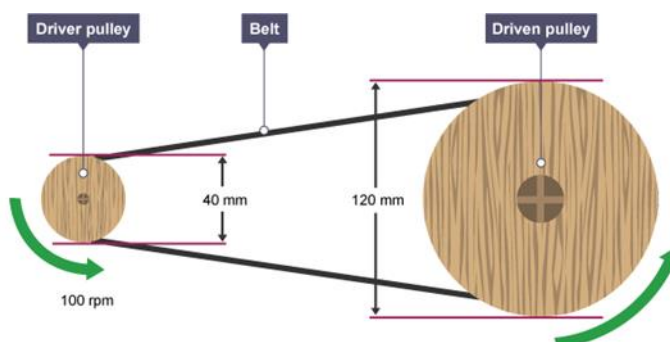

Velocity ratio = diameter of the driven pulley ÷ diameter of the driver pulley

$$= 120 \div 40 = \mathbf{3} \text{ or } \mathbf{3:1}$$

The smaller driver pulley turns three times to make the driven pulley turn once.

The output speed of the larger driven pulley can then be calculated using the information available - the input speed is 100 revolutions per minute (rpm) and the velocity ratio has been calculated as 3.

Output speed = input speed ÷ velocity ratio

$$= 100 \div 3 = \mathbf{33 \text{ rpm}}$$

Question 10

Calculate the velocity ratio and the output speed of the driven pulley on this lawnmower belt and pulley:

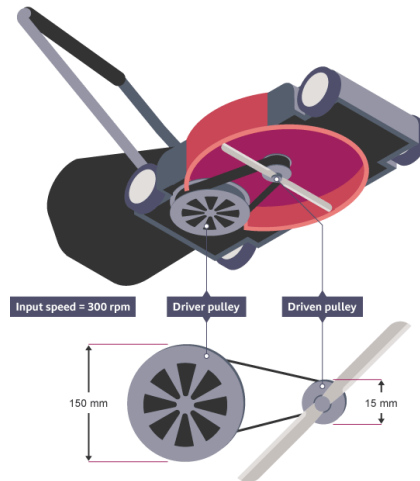

Material categories and properties

All materials have physical and working properties. Physical properties are the traits a material has before it is used, whereas working properties are how the material behaves when it is manipulated.

Papers and boards

Papers and boards are formed from wood pulp, which comes from trees. This squishy wood pulp is rolled out into thin sheets in paper mill factories to form the papers and boards that we use.

Paper	Physical properties	Working properties
Cartridge paper - used for drawing	Thick, textured, rough	Expensive and opaque, used for ink and watercolour
Tracing paper - used for developing ideas, to trace ideas from one sheet to another	Translucent (see-through), smooth	Shiny, takes pencil well
Copier paper - used for inkjet and laser printers to print from a computer	Thin, lightweight, bleached paper	Takes colour well, readily available, can jam printer mechanisms

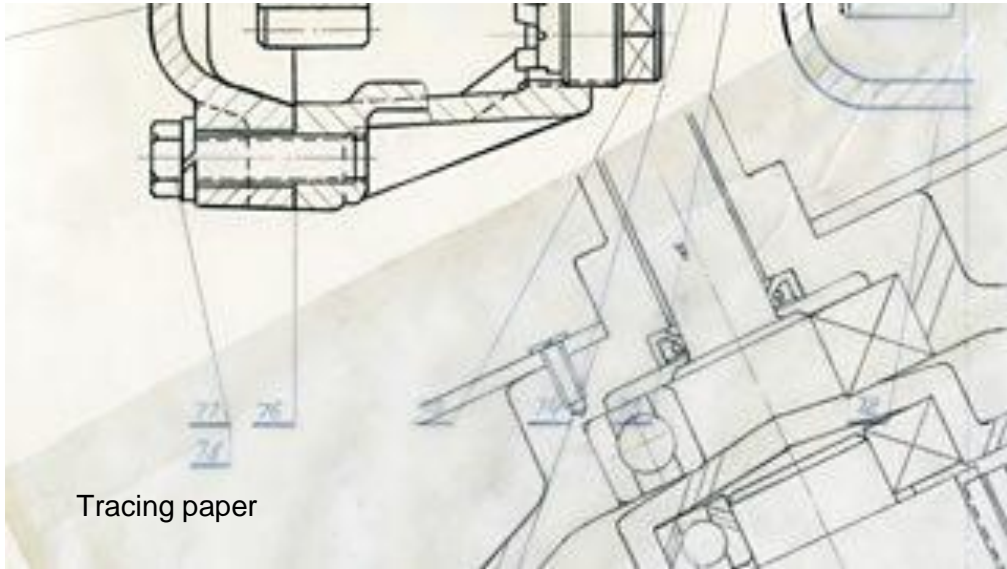

Board

Board thickness is measured in microns or grams per square metre (gsm) - the thinner the card the lower the microns or gsm.

Board	Physical properties	Working properties
Corrugated card - used for packaging electrical products (absorbs impact) or hot food (good insulator)	Paper bonded to the outside	Corrugations make it strong, protective and insulating
Solid white board - used for model making, packaging, cosmetic products	Smooth on both sides	Stiff, can be cut or scored
Folding box board - used for packaging food products, eg cereal boxes	Made of three layers - a printable top surface, an unbleached centre layer and a bleached inside layer	Good for scoring without splitting, accepts print well, not as strong as solid white board.

Corrugated card



Natural and manufactured timbers

Timber comes from trees. Trees have to grow to full maturity (between 25 and 100 years) before they can be cut down for wood.

Hardwood

Hardwoods come from **deciduous** trees, which have large flat leaves that fall in the autumn. Hardwoods take longer to grow, are not easily sourced and are expensive to buy.

Hardwood	Physical properties	Working properties
Beech	Slight pink tint, close grain	Tough, durable and smooth to finish
Mahogany	Dark-reddish colour, very close grain	Cuts and polishes easily, gives a fine finish, used for high-quality furniture
Oak	Moderate-brown colour with unique and attractive grain markings	Tough and durable, polishes well, used for quality furniture
Balsa	Pale and wide-spaced grain due to it being a fast-growing hardwood	Very soft and easy to form, often used to make models

Softwood

Softwoods come from **coniferous** trees. These often have pines or needles, and they stay evergreen all year round - they do not lose leaves in the autumn. They are faster growing than hardwoods, making them cheaper to buy, and are considered a **sustainable material**.

Softwood	Physical properties	Working properties
Pine	Pale coloured with aesthetically pleasing grain	Lightweight, easy to form, used for construction and decking
Cedar	Lightweight, pale colour with even texture	More expensive than pine but not as strong

Manufactured board

Manufactured boards are usually made from timber waste and **adhesive**. To make them more aesthetically pleasing they are often **veneered**. They are cheap to buy.

Manufactured board	Physical properties	Working properties
Medium-density fibreboard (MDF) - used for general carpentry work and flat-pack furniture as a veneer can be applied or it can be painted	Smooth, light brown, can be veneered	Smooth and easy to finish, absorbs moisture so not suitable for outdoor use
Plywood - used for furniture, shelving, construction and toys	Layers of veneer glued at 90 degree angles for strength, aesthetically pleasing outer layer	Easy to cut and finish, can be stained or painted



Plywood board

Ferrous and non-ferrous metals

Metals are found naturally and are mined from the earth. Metals used in products are **extracted** from the natural **ore** using large heat furnaces.

Ferrous metals

Ferrous metals contain iron and are **magnetic**. They are prone to **rust**, except for stainless steel and wrought iron.

Ferrous metal	Physical properties	Working properties
Mild steel - used for bike frames, car body panels and fixings (nuts, bolts, screws and nails)	An alloy that is grey and smooth, rusts if not protected	Ductile and tough, easy to form, braze and weld, versatile
Cast iron - used for wood and metal working vices, manhole covers, pans, gates and machine bases, eg pillar drill	Dull grey, rusts easily	Brittle if thin, can be cast in a mould
Stainless steel - used for kitchenware (cutlery, pots, pans and sinks)	Corrosion resistant, tough, resists wear	Difficult to cut

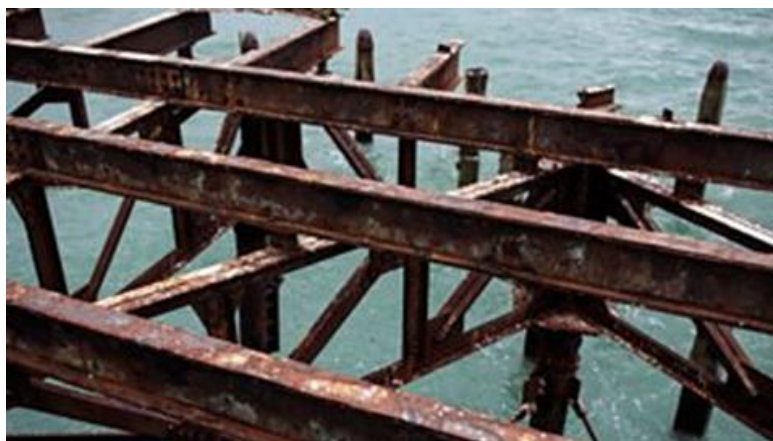

Orange, flaking rust on an old steel pier

Non-ferrous metals

Non-ferrous metals do not contain iron and are not magnetic. They do not rust.

Non-ferrous metal	Physical properties	Working properties
Aluminium - used for drink cans, kitchen utensils and some parts in transport	Light grey with a matt finish	Lightweight but strong and ductile
Copper - used for plumbing parts and electrical cable	Rose coloured, polishes well but can oxidise to a green colour (verdigris)	Good electrical conductor, can be polished, welds easily
Brass - used for musical instruments, eg trumpet, and a good choice for plumbing fittings	Yellow finish created by mixing copper and zinc together	Corrosion resistant, a good heat and electrical conductor, casts well

Copper oxidised to a green colour



Polymers

Most polymers are formed by processing **crude oil**. Rubber is a plastic that is found naturally.

Thermoforming polymers

Thermoforming polymers can be heated and formed repeatedly. They are **pliable** and **recyclable**, which is one of the biggest advantages of thermoforming polymers

Thermoforming polymer	Physical properties	Working properties
Acrylic (PMMA) - used for car lights, visors and baths	Hard, brittle, shiny, available in a wide range of colours	Resists weather well, can be cut, folded and polished well, scratches easily
High impact polystyrene (HIPS) - used for CD cases and yoghurt pots	Rigid, cheap, available in a lot of colours	Can be cut and vacuum formed easily, food safe but toxic when burned
Biodegradable polymers (biopol) - used for disposable cups	Can come in fibres or sheets	Lightweight, degrades over time so can safely be sent to landfill

Thermosetting polymers

Thermosetting polymers are **brittle** and can only be formed once. They are hard to recycle. They are good **insulators** and are resistant to heat and chemicals.

Thermosetting polymer	Physical properties	Working properties
Polyester resin (PR)	A resin and a hardener, sets clear and smooth	Strong, heat resistant and good insulator, used as waterproofing and for encapsulating items
Urea formaldehyde (UF)	Smooth finish, available in limited colours	Heat resistant, hard, brittle and easily injection moulded, used for electrical fittings

Textiles

Textile materials can be found naturally or can be formed synthetically. They can be processed into different forms such as **rolls**, **yarns** or **fibres**.

Natural fibres

Natural fibres come from plants or animals. They are easily **renewable** and **biodegradable**.

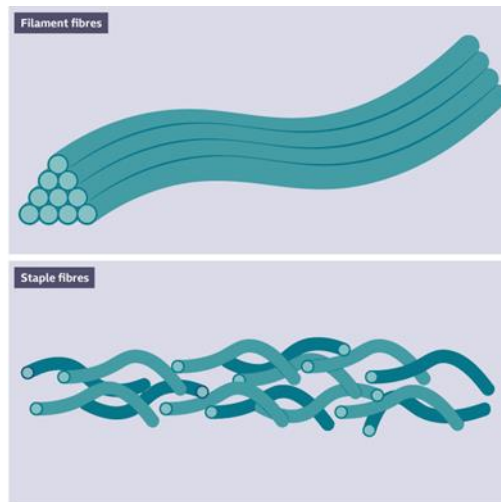

Synthetic fibres

Synthetic fibres are made mainly from **non-renewable** coal and oil **refined** into **polymers** and do not **degrade** easily

Synthetic fibre	Physical properties	Working properties
Polyester	Can be woven or knitted, thick or thin and available in a variety of colours, can be blended with other fibres for better properties (see polycotton)	Strong and versatile, it holds colour and washes well
Acrylic	Imitation wool, can feel stiff	Warm, dries quickly, poor absorbency, used for knitwear and blankets

Woven

Woven fabrics use a warp and weft yarn on a loom to interlock fibres.

Woven fabric	Physical properties	Working properties
Plain weave	Threads are woven in a simple under one, over one	Simple and cheap, eg calico, strong and available in different thicknesses, when torn it rips in a straight line
Twill weave	Twill weave has a diagonal pattern on the surface as the weft yarn is woven over two warp threads in a continual pattern	Strong, hardwearing, denim has a white warp and blue weft resulting in a two-coloured fabric

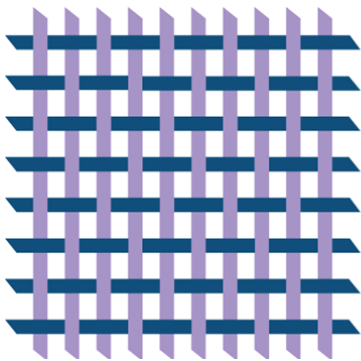

Plain weave (under one, over one)

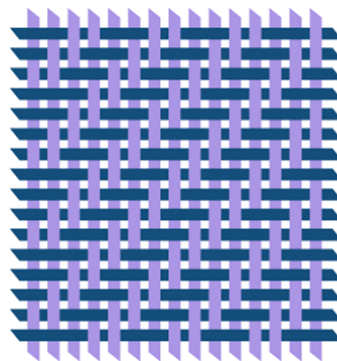

Twill weave (under two, over two)

Non-woven

Non-woven fabrics are webs of fibres that are glued, compressed or melted together.

Non-woven fabric	Physical properties	Working properties
Bonded fabrics	Fibres are visible and random, often has small holes on the surface	Does not fray as it has no grain, not strong
Felted fabrics	Randomly matted fibres, often wool, available in many thicknesses and colours	Formed with moisture, heat and pressure, can be shaped as it has no elasticity or drape, used for hat making

Felted fabric



Knitted

Knitted textiles made from rows of interlocking loops. They can be made from a variety of fibres, not just wool.

Knitted fabric	Physical properties	Working properties
Knitted fabrics	Can be warp knitted (straight lines) or weft knitted (knitted upwards), available in a variety of textures and colours, can have patterns knitted in.	Warm, stretchy and strong, tend to unravel when a hole is made, used in clothing and sportswear

Warp knit

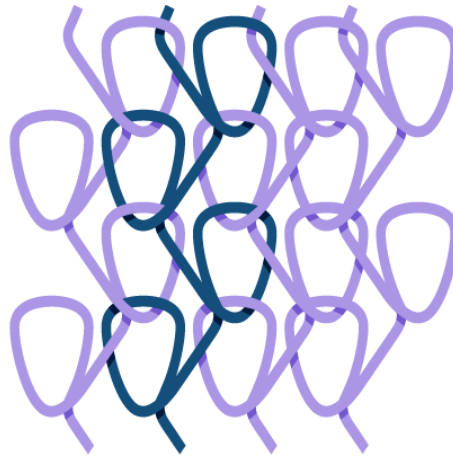

Design contexts

Designers need to ensure their designs are fit for purpose. Making informed material and manufacturing decisions can help ensure materials are conserved and the impact on the environment is reduced.

Material properties

Designers are required to use their understanding of material **properties** to make informed selections when designing products. When making a selection, two types of properties must be taken into consideration:

- mechanical - how a material will perform and react when exposed to external forces and loads
- physical - something that can be measured, like weight and size

Mechanical properties

Mechanical property	Definition
Durability	The ability of a material to withstand damage or wear
Ductility	The ability of a material to deform by bending, twisting or stretching
Strength	The ability of a material to withstand forces without bending or breaking
Malleability	The ability of a material to deform without cracking
Stiffness	The ability of a material to hold its shape without bending
Brittleness	When a material cannot absorb energy and will result in the material breaking into pieces
Hardness	The ability of a material to withstand indentation, scratching and wear
Toughness	The ability of a material to withstand impact without breaking

Physical properties

Physical property	Definition
Aesthetics	The appearance of a material, including colour and feel
Density	The amount of material contained in a set volume
Conductivity	The ability of a material to hold heat in or out (thermal) or the ability of electrical current to flow through a material (electrical)
Corrosion	The breakdown of a metal due to a reaction with water
Size	The measured dimensions of a material in two or three dimensions
Magnetic	The ability of a material to be attracted to a magnet

Manufacturing processes

The designer will consider many aspects when designing and developing a product, including the selection of a suitable manufacturing process. Below are elements a designer should consider:

Prototype

The designer may wish to prototype the final product using the material of choice to test how it could be manufactured commercially and whether the mechanical and physical properties of the material are meeting performance requirements.

Scale of production

The designer will need to consider the scale of production of the final product to ensure the product is affordable to manufacture:

- one-off production - this is the most costly as specialist skills are required to make a unique product, eg a commission for a statue
- batch production - this is cost-effective when a set quantity is required, eg masks for a festival
- mass production - this is cost-effective on larger production runs because the set-up cost is shared over a large number of products, eg ballpoint pens

Based on this, consideration will then need to be made to the material selection, the manufacturing processes and the associated tolling and running costs.

Material

A designer will make material selections based on two main aspects:

- the mechanical and physical properties of a material
- the availability of a material to meet the demand of production

Cost

A designer may need to put a costing **case study** forward before a product is able to go to manufacture. Cost factors that need to be considered include:

- Materials
- manufacture of components
- Labour
- Power
- Transportation
- waste management

Environmental, social and economic challenges

When a product is developed, consideration should be given to social, economic and environmental issues, such as the materials used, the product life cycle and how it will be recycled or disposed of.

Social, ethnic, economic groups and human capability

The needs and wants of a user will vary across different groups, and designers should consider this before developing their design ideas. Products should be sensitive to different groups' needs and should avoid having a negative impact, eg the use of religious or cultural symbols could cause offense if seen to be used inappropriately

Designers should consider:

- **social groups** - people who may share common interests or levels of education, eg liking the same sport or doing GCSEs, or who may be the same age or gender
- **economic groups** - based on occupation, status and financial security; what different economic groups can afford will vary - with the cost of products affected by quality and brand
- **ethnic groups** - people who may share a language, culture or belief(s)

In all cases, designers should try to create products without causing offense to any one group. For example, in Japan, some people may prefer to sit on the floor to eat their meals, whereas in Europe people are more likely to sit on chairs at a table. Therefore, furniture designs can differ for these audiences to make them suitable for use.

Human capability

A successful design should also ensure a variety of end users can use the product safely and effectively.

They might make adaptations with accessibility in mind, for example:

- a braille keyboard for those with sight difficulties
- a long shoe horn to allow an elderly person to put a shoe on without having to bend down
- fastenings such as Velcro for small children to use

Braille keyboard



Environmental, social and economic issues

There are several methods that designers can utilise to help create a more sustainable product, including:

- **fair trade**
- **carbon offsetting**
- product disassembly
- disposal of waste

Fair trade

Fair trade endorsed products help to ensure producers and workers receive a fair wage and safe working conditions, including preventing child labour.

Carbon offsetting

All manufacturers use energy, the level of which can be measured through their **carbon footprint**. A carbon footprint is the amount of carbon dioxide released into the environment through a particular activity, such as production or transportation. The bigger a product's carbon footprint, the larger its contribution to **global warming**. Companies can utilise carbon offsetting schemes to reduce the amount of energy they use, eg encouraging staff to use public transport, electric vehicles, walk or cycle to work, using **renewable energies** or planting trees.



Product disassembly

When creating products, companies can use parts that can be **recycled**, or **reused** by disassembly, or that will **biodegrade** when sent to landfill. Products made from several materials and components are difficult to recycle as it is difficult to separate the parts. Also, products that can be repaired or improved are likely to last longer.



Disposal of waste

It is important to reduce the amount of waste materials created in the manufacture of a product to ensure minimal impact on the environment. When a product wears out or is replaced, it should be disposed of in the most environmentally friendly way possible.



Recycling, reusing and green design

Creating a product uses resources that can have an impact on the environment, including raw materials and energy. **Global warming** and increased energy costs have led designers to consider the environmental impact of products and how they can be redesigned without affecting function.

When creating sustainable designs, designers should try to use:

- biodegradable materials** - this includes food scraps, cotton, wool, wood and biodegradable plastics. Carbon emissions are minimal in the production of biodegradable plastics, but there is a risk of contamination when they are recycled
- renewable energy** - this includes solar, wind, water, tidal and biomass; these methods often produce energy that doesn't pollute the environment, but initial installation costs can be high and the energy can be weather dependent, eg wind and solar
- less material or reduce waste** - techniques such as **nesting** can help to reduce waste, but it may not be possible to reduce or substitute materials and create a similar standard product
- recyclable or reusable materials** - many materials are not very sustainable, eg non-biodegradable plastics are made from oil, but alternatives are available and will mean less disposal

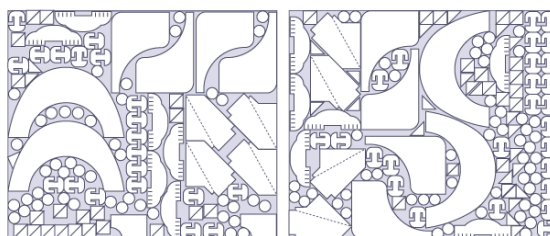

Nesting can help to reduce waste

Cost and manufacturing capability

The **cost** of making any new product is affected by many different elements, and consideration should be given to each of these during design:

- Labour
- equipment and manufacturing processes
- materials, ie quality and finish
- Energy
- overheads, eg rent, utilities, marketing, storage and business rates
- environmental, eg how much is recycled and reused and the disposal of any waste both during and at the end of production

From this consideration a designer can set a realistic price for their product. If the price doesn't cover the costs to produce it won't be viable as businesses can only make a profit if the price charged covers the production costs.

Example

To make a batch of garden sheds, a joiner has these costs to consider:

- labour = 40 hours at £10.00 per hour = £400.00 per week
- energy for the workshop = £95.00 per week
- materials = £120.00 per shed

If one shed sells for £250.00, how many sheds need to be sold for the joiner to break even in one week?

$$\begin{aligned}\text{Weekly costs} &= \text{labour} + \text{energy} \\ &= £400.00 + £95.00 = £495.00\end{aligned}$$

Profit = selling price - material costs

$$= £250.00 - £120.00 = £130.00$$

Amount to break even in a week = costs per week ÷ profit

$$\begin{aligned}&= 495 \div 130 \\ &= 3.8\end{aligned}$$

Therefore, **four sheds** need to be sold to cover costs and show a small profit:

$$£130.00 \times 4 = £520.00$$

$$£520.00 - £495.00 = £25.00$$

This yields a profit of **£25.00** each week.

Question 11

In the production of dog kennels, the following costs are incurred:

- labour = two workers for 40 hours at £10.00 per hour
- workshop hire and energy costs = £300.00 per week
- materials = £45.00

Each kennel sells for £200.00. How many dog kennels must be sold in one week to cover the costs of running the business?

Environmental impact

Life cycle analysis (LCA) assesses the environmental impact associated with a product, including:

- raw materials
- Manufacture
- Transportation
- Disposal

This makes it easier for the manufacturer to identify the areas that can be altered to reduce the possible environmental impact and cost of a product.

There are two different cycles:

- linear - ends with disposal, adding waste to landfill
- circular - continuous and incorporates recycling to ensure materials and products are used over and over again

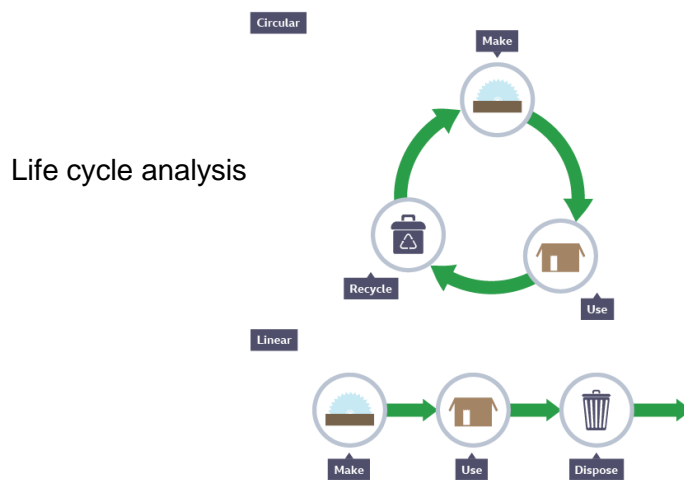

Life cycle analysis needs to be considered by the designer, the **manufacturer** and the **consumer** to reduce negative impact on the environment.

Investigating past work

Learning from and evaluating other designs to identify features that could be improved, eg changing materials, can help make a new design more successful or appealing to its target audience.



This process benefits the designer in a number of ways:

- it helps to avoid copying other designers' work - this is called **plagiarism**
- it identifies features or aspects of existing products that could be improved, eg reducing the cost, adding extra features, making it easier or more comfortable to use, or making it look more attractive to certain groups
- it can identify technologies or ideas that could be transferred or applied to a new function or area

The research from analysing existing products can be collated and used to inform your **design specification** and design ideas. It can also help work out the cost of manufacturing a product, including how much material is needed and what machinery is required. The percentage profit can be worked out from this and can be improved by lowering production costs, eg by using cheaper materials or fewer workers.

The following questions can help with analysis:

- Aesthetics** - What does the product look like? What is the colour, texture, pattern and decoration of the product?
- Client and user requirements** - Who would buy the product and when would they use it? How well does the product do its job when compared to others? How marketable is it to the user?
- Environment** - Is the product sustainable and/or environmentally friendly? Is it recyclable? Can it be easily repaired rather than thrown away?
- Size** - What is the size of the product? Is it comfortable to use? Is it a similar size to other products with the same use?
- Scale of production** - Which processes were used to make the product? Which type of production method was used (one-off, batch or mass)?
- Cost** - How much did it cost to make? How much does it cost to buy? Is it considered good value by the consumer?
- Function** - What is the function and purpose of the product? How well does it work? Could it be improved?
- Materials and components** - What materials and components have been used to make the product? Why were these materials and components used?

Designers and design companies

Below are a variety of past and present designers and design companies who have become known for a particular style or approach to design:

Alessi



During the 1970s, Alberto Alessi began employing product designers to make original and fun designs for everyday kitchen equipment. The bright colours and stylish designs were mass produced and affordable to everyone.

Apple



Jonny Ive led the design team at Apple who took the existing 'less but better' ethos to create the iPod and iPhone. Their concentration on intuitive design combined with sleek edges has become instantly recognisable.

Heatherwick Studio



Heatherwick Studio was established in 1994 in the UK by Thomas Heatherwick. It comprises a group of designers and architects who have worked on projects from The Rolling Bridge in London to perfume bottles.

Joe Casely-Hayford



Joe Casely-Hayford was a British fashion designer with an international reputation for British tailoring.

Pixar



Pixar Computer Animation Film Studios was one of the first to develop new computer technology to produce well-known animated films.

Raymond Loewy



Raymond Loewy was a French industrial designer whose concept of 'beauty through function and simplification' resulted in many designs that are still recognisable today, such as the Coca Cola bottle and the Le Creuset Coquette dish.

Tesla



Tesla is an automotive and energy storage company specialising in the manufacture of electric vehicles, lithium battery energy storage and solar panels.

Zaha Hadid



Zaha Hadid was a British-Iraqi architect who promoted architecture as a visual art form, integrating geometric and sweeping fluid forms.

Design strategies

Designers use iterative design to simulate the design methods used in industry.

Designers continually test, evaluate and refine ideas using a variety of methods to ensure designs meet user needs.

Collaboration and design fixation

It is important for a designer to use a variety of **design strategies** to be able to generate the most **innovative** and functional solution to a design problem. This will help to gather information and feedback from others to ensure the best design to fit the brief is created. Different projects might benefit from different kinds of design strategy.

Collaboration

Working with others is an excellent way of gaining feedback for designs. Many companies use groups of designers with different tastes, ideas and specialities to allow a diverse range of opinions to be acted on.

Effective collaboration between designers, manufacturers and the target audience can help to create a successful product. When a diverse team works closely together, especially during the early design stages, and revisit the designs as part of the **iterative design** process, it can lead to a highly innovative product.

Try using a design process called **SCAMPER**, which is a mnemonic for seven thinking techniques that help create solutions to problems:

- **Substitute** - What can be changed for something else?
- **Combine** - How can materials or designs be combined?
- **Adapt** - What can be adapted or altered?
- **Modify** - Could it be changed or expanded?
- **Put (to another use)** - Could the design have a different use?
- **Eliminate** - What parts of the design could be deleted or removed?
- **Reverse** - How could this product be reorganised?

Design fixation

The first idea a designer comes up with might not be the best one, but they might pursue it because it has worked for them before and they feel they should try it again. Alternatively, the solution to the problem they are trying to solve might already exist, and designers might find it difficult to think of anything else. As well as this, the client might be fixated on what they expect the product to be and not be open to any new ideas that are proposed

Becoming **fixated** on a particular idea can become an issue when trying to develop a new solution to a design problem. This can be avoided by:

•Collaboration

- feedback from **user groups**
- testing a product

User-centred design

User-centred design is a different style of designing from [iterative design](#), as it bases the design of a product around the needs of the **target market** rather than the continual development of **iterations**. The user is questioned and consulted throughout the development, and evidence is gathered through questionnaires, interviews, testing and observations, and the results are used to improve the product.

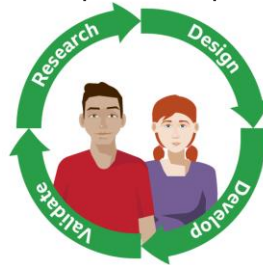

User-centred design involves putting the end user at the centre of every decision made during the design process and, as a result, the end product is more likely to fit their needs. However, it can make the process take longer and the end product can become limited to one specific type of user rather than a group. Focusing on the user needs throughout the design process can reduce the development time as any changes that may be required are implemented in the early stages.

Systems approach

Systems thinking

This refers to the understanding of a product or component as part of a larger system of other products and systems. Attention should be paid to the role of all components and sub-systems of the product or system, including the user experience and the marketing of the object being designed. This ensures all aspects of the product are given the attention to detail required.

Systems approach to designing

Designing certain products, eg electrical products, may require a different technique known as a **systems approach**. This logical approach is particularly useful in electronics where there is an **input, process and output**, as each stage has to perform a specific function before moving on to the next step. In the case of designing an electric piano keyboard, the input is pressing the key, the process is generating the correct music note and the output is sound through the speaker.

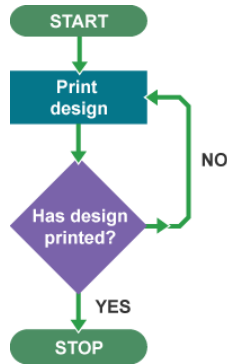

The systems approach should not be confused with **schematic diagrams**, which show how an electronic **system** should be connected together. A systems approach **flowchart** relates specifically to the design of a process. Different shapes in a flowchart represent different types of operation, and these shapes have the same meaning worldwide.

Symbol	Name	Function
	Start / End	An oval shape represents the start or end of a process
	Input / Output	A parallelogram represents input or output
	Decision	A diamond represents a decision
	Process	A rectangle represents a process
	Arrow	An arrow is a connector that shows relationships between the different shapes and what they represent

Quality assurance (QA) decisions can also be added during the design process to ensure that problems are picked up and fixed within the system, eg a decision stage checking the **dimensions** of a part that has been manufactured.

Iterative design process

The **iterative design** process is revisited and reflected upon at regular points in order to improve and refine design ideas to ensure they best meet the needs of the final user.

Designing a product for a **client** can be done in several ways. **Manufacturers** cannot risk investing large amounts of money into the production of a product that has not had adequate design, modelling, testing, **prototyping** and **evaluation**.

Iterative design is a circular design process that models, evaluates and improves designs based on the results of testing.

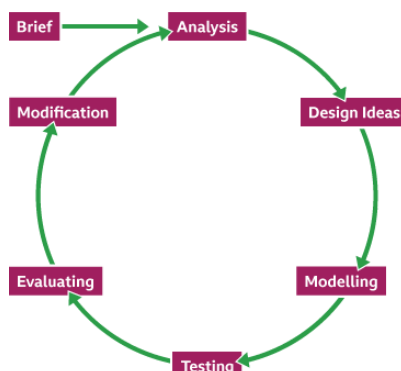

•**analysis** - starting with a context or **design brief**, a designer may explore the design issue and generate ideas to solve the design problem

•**design ideas** - create a series of **freehand sketches** of design ideas that may help to solve the problem

•**modelling** - **modelling** ideas in card, paper, clay or other materials can create a cheap and quick way to do initial trials with a product

•**testing** - once a model has been made it can be tested in a variety of ways:

- **destructive testing** - tests the product to its extreme to see what conditions it can tolerate before being destroyed to help decide on the best materials and construction methods to use
- **non-destructive testing** - tests the model to identify areas of weakness without destroying it to test the function of the product and highlight any unexpected design flaws
- **market testing** - tests the product with its **target market** to give feedback on performance and design

•**evaluating** - the data gathered from the testing of a model should be evaluated to highlight any modifications that need to be made at the next stage

•**modification** - from the evaluation, a designer can revisit the models and design ideas to make improvements

Freehand sketches



Communication of ideas

There are a variety of techniques, materials and media that designers can utilise while developing their ideas. Each provides a different function and allows designers to communicate ideas effectively.

Sketching and annotation

Freehand sketching is the quickest way of getting your initial designs on paper before an idea is forgotten. Freehand sketches are often done without a ruler or template and instead are produced quickly and freely. They can be shown in 2D or 3D. 3D drawings encourage the designer to consider what the product looks like from different angles and whether or not they need to adapt or change their ideas.

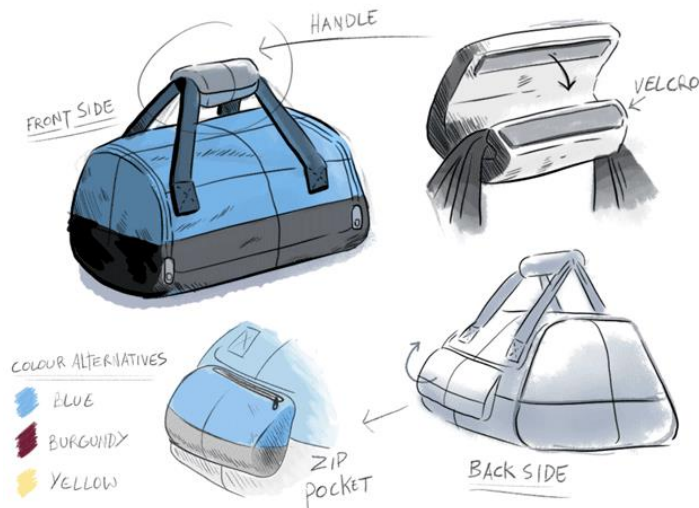

Annotation can be added at any point to show key parts, sizes, materials, **components** and **construction**. The use of shading, colour and different viewpoints can be an easy way of communicating initial ideas.

Formal drawings are a more precise or less messy style of drawing; they can be done by hand or with **computer aided design (CAD)** packages.

Formal hand drawings would use tools such as rulers and set squares to ensure accuracy and neatness. Using computer aided design (CAD) allows the user to quickly make changes, and the drawings can be digitally shared and copied with ease. Formal drawings are used when showing an idea to a **client**, showing measurements or getting feedback from a **user group**.

Isometric and oblique projection

Isometric drawings and **oblique projections** are both often used by engineers as part of their technical drawings and illustrations.

Oblique projections

Oblique projections are created using **oblique grid paper** and use 45-degree lines to create a 3D graphical image. Oblique drawings are not very realistic as it is impossible to see the front of an object straight on and the side at the same time. They can be useful to sketch at speed or to show the front and side of a building.

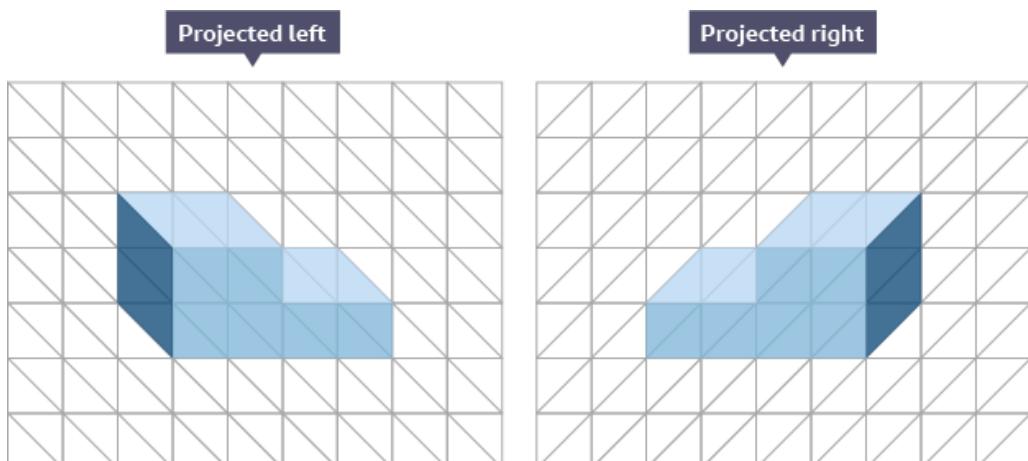

Isometric drawings

Isometric drawings are commonly used in technical drawing to show an item in 3D on a 2D page. Isometric drawings, sometimes called isometric projections, are a good way of showing measurements and how components fit together. Unlike perspective drawings, they don't get smaller as the lines go into the distance.

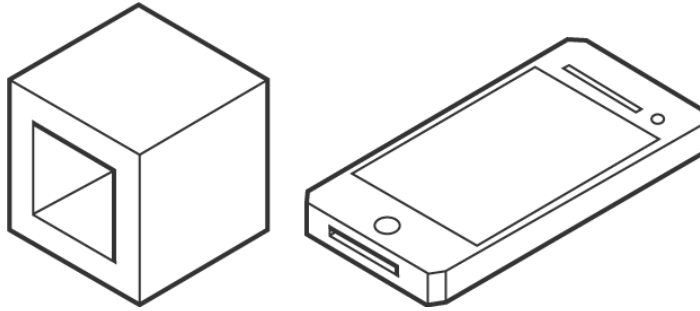

There are three main rules to isometric drawing:

- **horizontal** edges are drawn at 30 degrees
- **vertical** edges are drawn as vertical lines
- **parallel** edges appear as parallel lines

Isometric paper can be used to draw 3D shapes - for example the cube below is drawn using the dots as a guide. The vertical lines always remain vertical, but the horizontal lines are at angles.

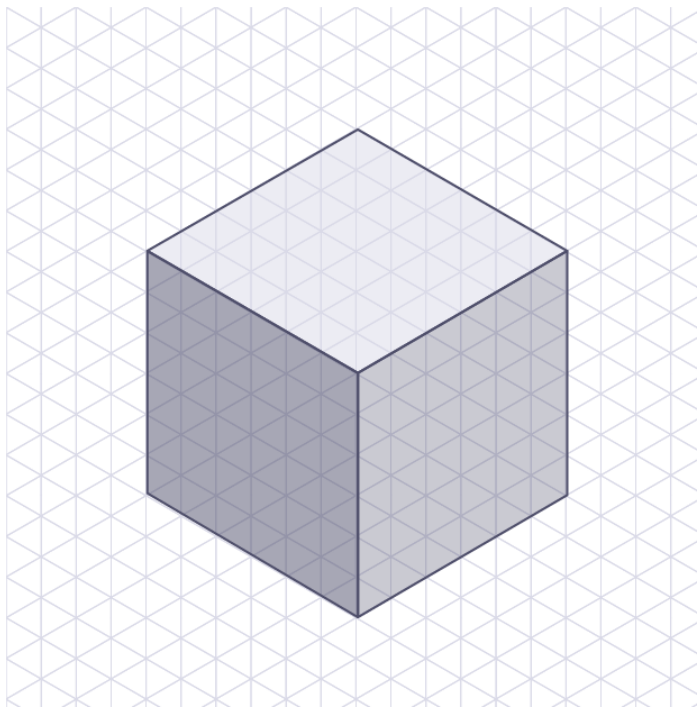

Isometric drawings can be used to show the scale of a product as well as a 3D representation.

Example

Below are two cubes drawn in isometric:

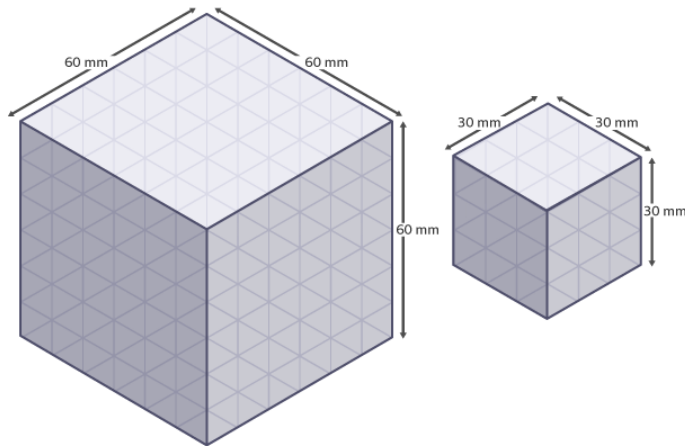

Scale factor = smaller length \div larger length

$$= 30 \div 60$$

$$= 0.5$$

This means the second cube has been drawn to **half scale**, also written as 1:2.

Question 12

Work out the scale factor of the smaller cuboid below:

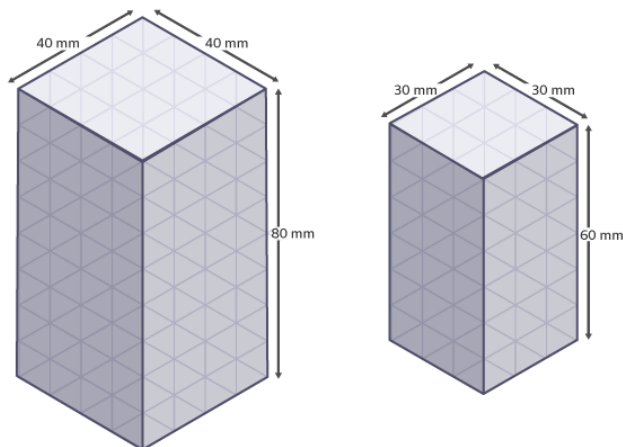

Perspective drawing

Perspective drawings are commonly used in technical drawing to show an item in 3D on a 2D page. Perspective drawings show an object in 3D getting smaller in the distance.

Single-point perspective - This shows an object from the front in a realistic way as it gets smaller going into the distance. The front view goes back towards a **vanishing point**, which is a point on the horizon line where all lines meet.

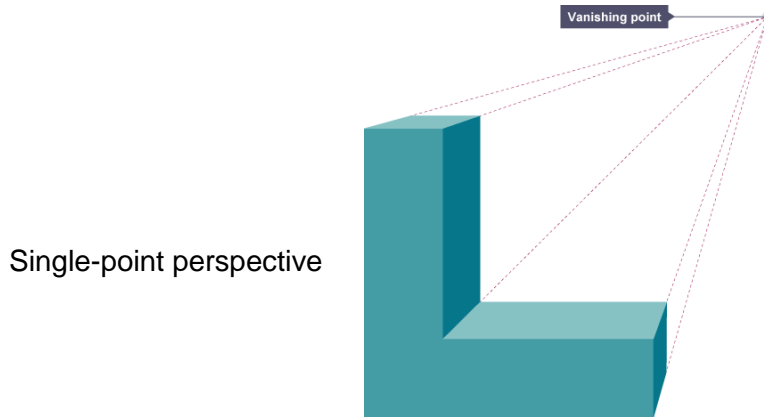

Two-point perspective - This shows an object from the side with two vanishing points. It gives the most realistic view of a product as it shows the item edge on, as we would see it. It is often used to produce realistic drawings of an object.

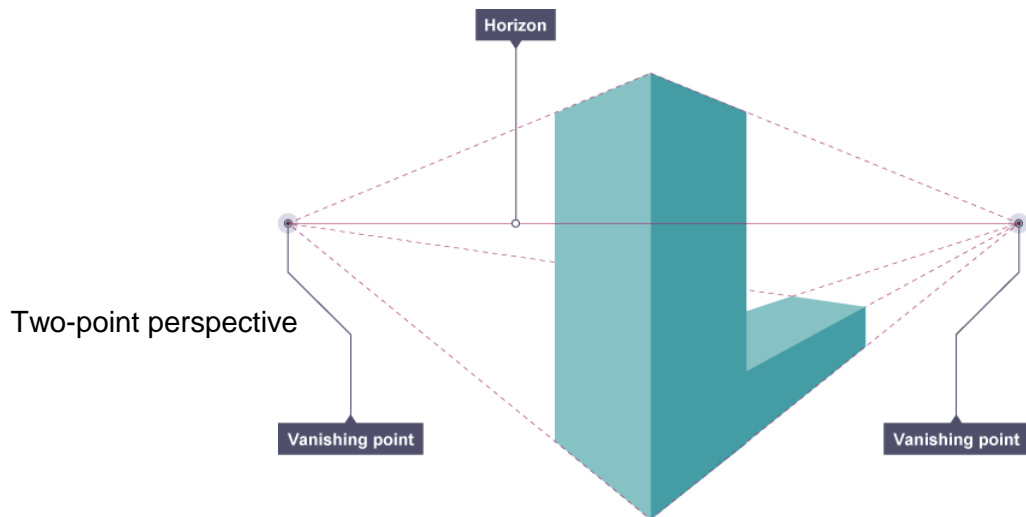

Single-point perspective is often used by **interior designers** to show a view into a room, whereas two-point perspective is often used by **architects** to show realistic building ideas.



Interior design in single-point perspective

Three-point perspective

Three-point perspective is similar to two-point perspective because two of the vanishing points remain on the horizon line. The third perspective point is vertical, which makes the drawing look smaller not only to the left and right on the horizon, but also as the eye looks downward. Three-point perspective is used by many product designers when they sketch a product. It looks the most realistic, but it is also the hardest to draw.



Three-point perspective

Systems diagram and **schematic diagrams** are specifically for electronic and mechanical systems.

System diagrams

Designing certain products, eg electrical products, may require a different technique known as a **systems approach**. This logical approach is particularly useful in electronics where there is an **input, process and output**, as each stage has to perform a specific function before moving on to the next step.

Block diagrams can be written, usually in boxes, with the headings input, process, and output. When planning how a circuit will function, these headings are then used to **plan what the input, process and output could be**.



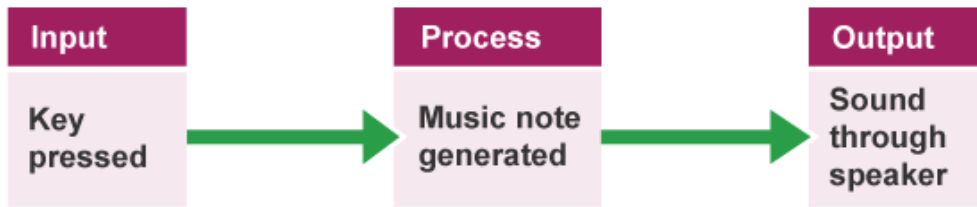

In the case of designing an electric piano keyboard, the input is pressing the key, the process is generating the correct music note and the output is sound through the speaker. Systems approach should not be confused with **schematic diagrams**, which show how an electronic **system** should be connected together.



Example of a block diagram

Systems approach flowcharts

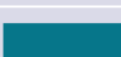
A systems approach flowchart relates specifically to the **design of a process**. They can be used for programming a circuit so that a programmable chip can process an input and then turn on an output. Different shapes in a flowchart represent different types of operation, and these shapes have the same meaning worldwide.

Symbol	Name	Function
	Start / End	An oval shape represents the start or end of a process
	Input / Output	A parallelogram represents input or output
	Decision	A diamond represents a decision
	Process	A rectangle represents a process
	Arrow	An arrow is a connector that shows relationships between the different shapes and what they represent

Quality assurance decisions can also be added during the design process to ensure that problems are picked up and fixed within the system, eg a decision stage checking the **dimensions** of a part that has been manufactured.

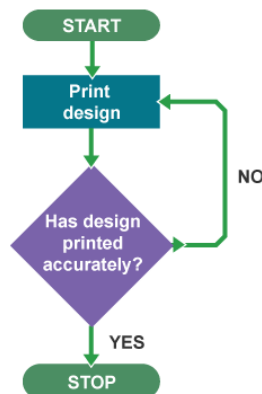

An example flowchart for printing a design, including a quality assurance decision

Schematic diagrams

Schematic diagrams use **symbols** to show the layout of electrical or mechanical **systems**. A **circuit diagram** is a schematic that shows how **components** are connected up.

This schematic shows a simple circuit, which includes a battery and a switch

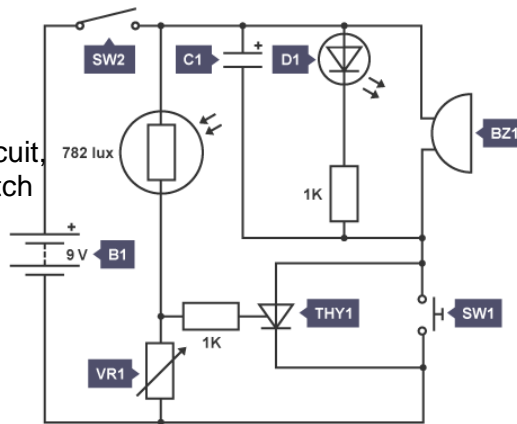

Schematics can also be used in repair **manuals**. Symbols are simplified and look nothing like the physical components themselves, and the schematic diagram never makes a reference to the position of components on a circuit board.

The schematic diagram describes the points of electrical connection only, and these are shown as dots. The symbols are not drawn to scale so don't have **dimension** information, and they can be spaced out to avoid looking jumbled or overly complex.

Producing a schematic drawing on a computer is far neater than drawing it by hand, with computer programs available to quickly create accurate and neat schematics that can be easily shared with others.

2D and 3D drawing techniques

Orthographic projections

Orthographic projections are **working drawings** in either a first or third angle projection and show each side of a design without **perspective**, ie a 2D drawing of a 3D object. They are used to show an object from every angle to help manufacturers plan production. Starting with a front view of a product, **construction lines** show where areas join and are used to draw a side and plan (top) view, ensuring that the drawing is accurate from all angles. These drawings are **to scale** and must show **dimensions**.

First and third angle projections

First angle projections and **third angle projections** are the two types of orthographic drawing, also referred to as 'working drawings'. The difference between first and third angle projection is in the position of the plan, front and side views.

Orthographic projections have a set of standard lines to show different aspects of the diagram. These lines allow complex shapes to be drawn simply in 2D.

Outlines	—————
Construction lines	—————
Hidden details
Dimension arrow	←———— 3 cm —————→
Centre line	— · · · — · · · —

In third angle, what you see from the right would be drawn on the right. In first angle, the view from the right would be projected through and drawn on the left. The views in first angle are depicted as if you were looking at an x-ray of the object.

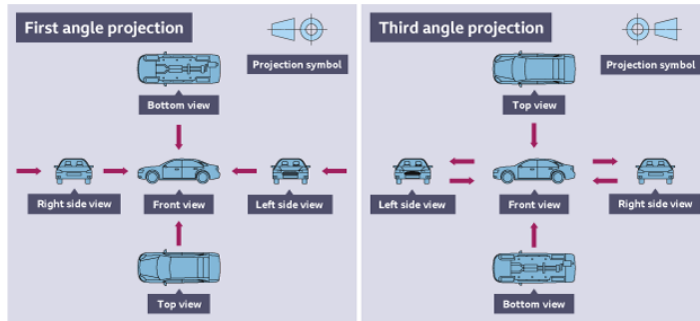

In a first angle projection the plan view is below the side view. In a third angle projection the plan view is above the side view.

First and third angle projections use these symbols on a diagram to indicate which projection they are:

Projection	Symbol
First angle	
Third angle	

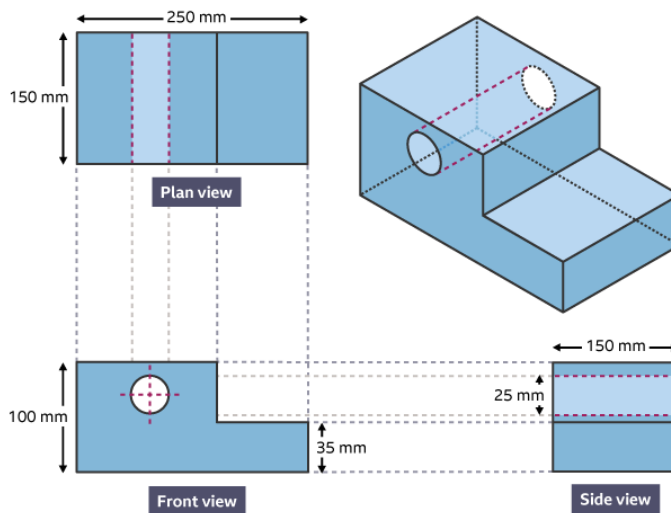

Assembly drawings

Similar to exploded views, an **assembly drawing** will show how the parts of a product fit together and where components should go. They are often used to show how to put together flat-pack furniture or model kits.

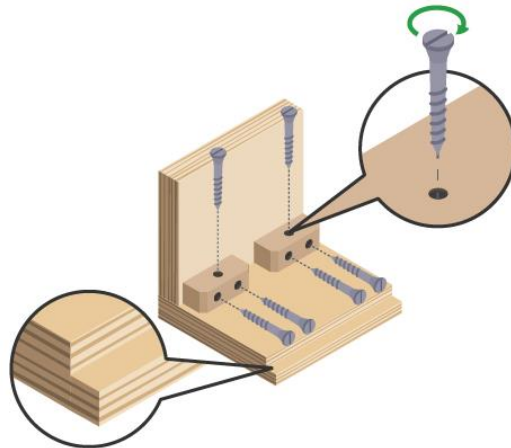

Assembly drawing

There are two types:

- **fitted assembly** - shows the parts put together and can be drawn in 2D or 3D
- **exploded diagram** - shows the parts separated, but in the correct relationship for fitting together, usually drawn in 3D

Exploded diagrams

Exploded diagrams show how a product can be assembled and how the separate parts fit together, with dotted lines showing where the parts slide into place. The diagrams also show components that would usually be hidden in a solid drawing.

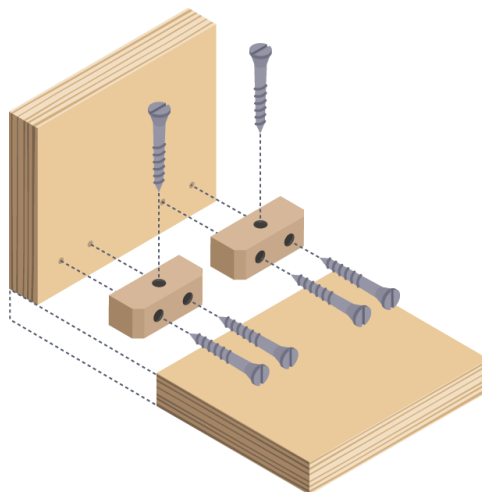

Exploded diagrams can take the place of detailed written instructions, meaning they can explain the construction of something without the barrier of different languages. They are widely used as instructions for self-assembly furniture.

Digital photography and media

Digital photography saves images or photos as digital files so that they can be edited on a computer, phone or tablet to help develop ideas.



Audio and video recordings can help when gathering evidence and information to help make design decisions.

Interviews

Audio recordings of **client** interviews and **user feedback** can be a less-invasive way of gathering information than video. Recordings can be listened to repeatedly to **analyse** information, and recording equipment is easily available on **smartphones**.

Photographs

Taking photographs to record every step of development and collecting evidence helps keep track of each stage of research. Photographs can be used to record information, such as site surveys, **anthropometric data** and **ergonomics**, as well as being a reference point between the designer and the client.

Videos

Video evidence can be used to help remember client or **user group** interviews. They can also be used to film **user trials**, where slow-motion replays or **time lapses** can be shown to identify very specific moments, such as breaking points or areas of **wear**.

The permission of the client or user should always be given before recordings of any of the above methods are made.

CAD

CAD modelling

When a **computer aided design (CAD)** drawing has been made, a product can be shown from all angles on screen, and colour, materials and **components** can be quickly changed. This allows designers to discover aspects of the product, eg the most economical way of cutting a material or how stresses and loads will perform on it, without costly physical modelling. Ideas can also be shared quickly around the world using the internet.



CAM modelling

computer aided manufacture can help produce full-size or **to scale** 3D models of a product. A designer can create the design in CAM, or input an existing 2D CAD drawing.

The **coordinates** are automatically generated and use X, Y and Z values to build a model on a 3D printer, using points on an invisible grid.

X, Y and Z coordinates

All drawings start from the 'origin', which is the point where X and Y meet.

As **x** increases, the point on the axis moves further away from where **x** and **y** meet, and when **x** decreases, the point moves back towards the intersection. As **y** increases, the point moves further up, away from the **x** and **y** meeting point, and when **y** decreases, the point moves down again.

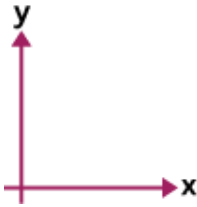

An **x** and **y** coordinate creates a point on a 2D grid that can be used on machines, such as a **laser cutter**, that only cut flat materials. A **z** coordinate is added to make the point become 3D and can be used to build objects on machines such as a 3D printer.

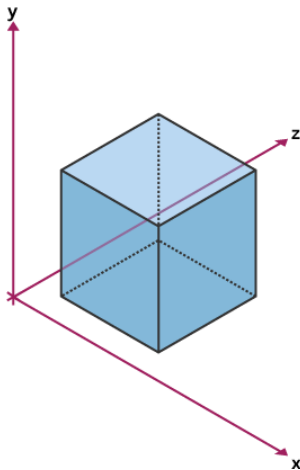

3D modelling

Making a model allows designers to visualise and test how a product looks and performs in 3D and is a great way of checking a product's viability.

Modelling can be time-consuming and expensive, but a physical model allows a person to see and handle a product, unlike viewing it on a screen through **computer aided design (CAD)**. **Computer aided manufacture (CAM)** models made on a 3D printer using a CAD drawing are very accurate but also expensive, time-consuming and limited to 3D-printable materials. Product designers can use easy-to-form and easily accessible materials, eg **balsa**, **jelutong** and cardboard, to create models quickly and cheaply.



A 3D model of a bedroom

Quick textile designs can be modelled out of newspaper and more-detailed models can be made from cotton or **calico**. Fabric models are called **toiles** and can be made on a **mannequin** to test the **dimensions** and drape of a **garment**.

Breadboards are used in the early development of electronic products. They are boards containing a series of holes that **electrical components** can be pushed into to allow current flow without making a permanent join. Components can then be easily swapped to improve or fix a **circuit**.

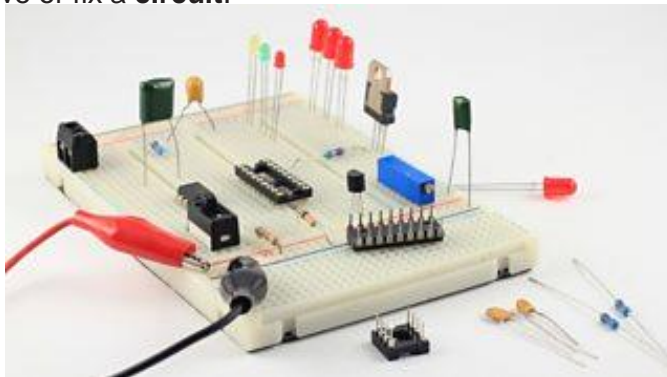

Example of a breadboard

Advantages of physical modelling	Disadvantages of physical modelling
Allows a designer to physically handle a design and view from all sides	Can be time-consuming and complicated
Changes can be made quickly and easily	3D printed models can be expensive and have limited materials available
Materials such as cardboard can be found cheaply and easily	Models can't generally be used for testing as they don't use the same materials that the product will be made of
Models can be scaled up or down in size	
Models can be used to show to a client and get feedback on before production	

MATERIALS
METALS
For Metal
Students Only

Metals

Metals come from an ore that is mined from the ground. Metals can be used for all methods of production, from bespoke pieces of jewellery to mass-produced cars

Sources and origins

Metals are found in ore-bearing rocks that form a part of the Earth's **crust**. Ore-bearing rocks will contain one or more types of metal that can be processed to separate the metal from the waste material. They vary from country to country:

- USA, Russia and Sweden are the main suppliers of **iron**
- China is the main supplier of **steel**, which is processed from **iron** ore
- USA, France and Australia are the main suppliers of **aluminium**, which is processed from **bauxite**
- USA, Chile, Zambia and Russia are the main suppliers of **copper**, which is found in **chalcopyrite**
- Indonesia and China are the main suppliers of **tin**, which is found in **cassiterite**

Iron ore is used to make iron and **steel**. **Copper** is easily extracted, but ores rich in copper are becoming more difficult to find. Aluminium and titanium are metals with useful properties, but they are expensive to extract. Most everyday metals are mixtures called **alloys**.

Extracting metals

The Earth's **crust** contains metals and metal **compounds** such as **gold**, **iron oxide** and **aluminium oxide**, but these are often mixed with other substances when found in the Earth. To be useful, the metals have to be extracted from whatever they are mixed with. Metal ore is a rock containing a metal, or a metal compound, in a high enough concentration to make it economic to extract the metal.

The method used to **extract** metals from the ore in which they are found depends on their **reactivity**. For example, reactive metals such as **aluminium** are extracted by **electrolysis**, while a less-reactive metal such as **iron** may be extracted by **reduction** with carbon or carbon monoxide. The method of extraction of a metal from its ore depends on the metal's position in the **reactivity series**:

The reactivity series for different metals

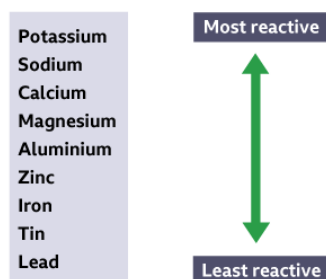

Electrolysis	Reduction
Potassium	Zinc
Sodium	Iron
Calcium	Tin
Magnesium	Lead
Aluminium	

Characteristics and properties

Each material has properties that make them good for specific tasks, eg aluminium is lightweight and doesn't rust, making it suitable for drinks cans. The properties of materials must be considered when designing a product, eg a steel pan handle would conduct too much heat and burn the user.

Physical properties are the traits a material has before it is used. Working properties are how a material behaves when it is manipulated.

Metals display the following working properties:

- **malleability** - being able to bend or shape easily would make a material easily malleable, eg sheet metal such as steel or silver is malleable and can be hammered into shape
- **ductility** - materials that can be stretched are ductile, eg pulling copper into wire shows it is ductile
- **hardness** - the ability to withstand **impact** without damage
- **durability** - the ability of a material to withstand wear or damage
- **toughness** - the ability of a material to absorb shock without breaking
- **elasticity** - the ability of a material to bend without cracking
- **tensile strength** - the ability of a material to withstand a pulling force without stretching
- **compressive strength** - the ability of a material to withstand a pushing force without being squashed

Social and ecological issues

When considering the ecological and social implications of using metal, its **non-renewable** nature is the main concern. Metal cannot be grown and is a **finite resource** - there is only a certain amount within the Earth's **crust**.

To create **aluminium**, the ore **bauxite** is mined as it contains aluminium hydroxide minerals. The bauxite is **purified** so that **aluminium oxide** is produced, and the aluminium is **extracted** from this through **electrolysis**. Huge amounts of energy are used to extract aluminium and convert it into a usable material. Recycling it requires some energy to make it usable again, but nowhere near as much.

Whenever environmental impact is being reduced, '**The 6 Rs**' can be called upon to ensure an in-depth analysis has been done. The 6 Rs can be considered by the designer, the **manufacturer** and the customer.



The 6 Rs

The term 'the 6 Rs' can be applied to the design of new products or when a product is finished with, used up or no longer wanted. Here are some questions to prompt 6 Rs thinking:

- Reduce** - Can the amount of metal used be reduced? Can the metal be bought locally to reduce product miles?
- Reuse** - Can the metal be reused for another purpose once a product is finished with?
- Recycle** - Can the metal be disposed of correctly so that it can be recycled?
- Rethink** - Can the way a product is made be redesigned so that less metal is used?
- Refuse** - Refusing to use metal could be a consideration; could a material that is sustainable be used instead?
- Repair** - When a product is broken, can it be repaired rather than discarded?

Ecological footprint

Metal ore is found in the Earth's crust and the extraction and processing of the metal ore has an impact on the environment. The **ecological footprint** helps designers and industry consider how the impact from mining for metal ore can be minimised. There are 6 aspects that form the ecological footprint.

These are:

- Sustainability** - Ore is a finite resource, which means it is **non-renewable**. Recycling metals can help ensure they are available for future generations.
- Extraction and erosion of landscape** - As ore is found in the Earth's crust, extraction involves clearing the land so that mining can take place. This can lead to **deforestation**, soil erosion and loss of habitat for wildlife.
- Processing** - Ore has to be removed from rocks and other minerals, which requires a lot of energy to process.
- Transportation** - Ore is usually found in remote areas that have limited or no transport links. A transport infrastructure often needs to be built to allow heavy goods vehicles to transport the ore to a processing site.
- Wastage** - Processing leads to a large amount of waste material that often need to be processed again before being disposed of.
- Pollution** - Extraction of the ore involves the use of heavy equipment that produces noise pollution. The heavy goods vehicles used to transport the ore release carbon dioxide and other gases into the environment.

Selecting metals

Materials can be selected based upon their **working properties**. It is important to know and understand which materials can be used for a specific purpose:

- How do they look?
- What are they commonly used for?
- How can they be manufactured?
- How do they perform in use?
- What makes them unique - are they the most **durable**, the lightest etc?
- Will the cost of the material make the product feasible?

Many products are made from metal, and understanding the way each metal will function is vital. For example, if a metal is needed for strength and lightweight **properties**, then **aluminium** could be a possibility. Many sports cars are made of aluminium, as are aeroplane shells and wings.

Alloys are made by combining different metals to produce another that is more useful for a specific task. **Stainless steel** is an alloy of **iron** and **chromium** (from 10.5 per cent to 27 per cent). The chromium produces an oxide layer on the outer surface of the **steel** and prevents **corrosion**. Stainless steel is often used for kitchen utensils as it will not **rust** and can be wiped and cleaned with ease.



Metals offer a wide variety of **aesthetic** qualities - some, like **lead**, are dull, and some can be polished to a mirror-like finish. Metals can be smooth after **machining** or textured after being **cast**.

Metals come from an **ore** that is mined from the ground. A huge amount of heat energy is needed to extract the metal from the ore - this energy often comes from **fossil fuels**. Metal ores are **non-renewable**, meaning they are a **finite resource** and therefore **recycling** metal is important.



Iron ore

The cost of metal varies massively and some metals will become harder to obtain in future years. Common metals, such as steel, are relatively cheap, whereas **gold** and **platinum** are considerably more expensive. Metals can be used for all methods of production, from **bespoke** pieces of jewellery to **continuously produced** cars. Bulk buying of metal will reduce the cost. Most **stock sizes** of metals will have a price that is based on the weight of the metal.



Gold used for jewellery

Example

If aluminium costs £1,450 per tonne, calculate the cost of a 1 m length of 20 mm² section aluminium bar that weighs 1 kg.

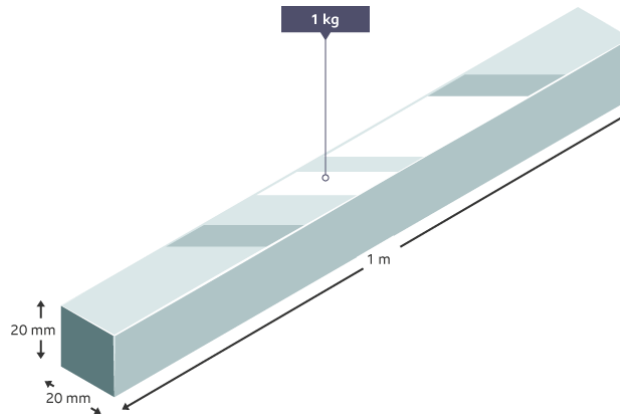

Cost = cost per tonne ÷ weight required

1,000 kg = 1 tonne, so:

$$= 1,450 \div 1,000$$

$$= 1.45$$

Cost for the metre length = **£1.45**

Remember to read questions carefully to identify the information that is relevant to the calculations.

Question 13

Aluminium weighs approximately 2,600 kg per cubic metre (m³).

Based on this, how much would a 1 m length of 20 mm² section aluminium weigh?

Stock forms

All designers need to know the **stock sizes** that metals and **alloys** are available in. If stock sizes are known, designs can be manufactured more economically to reduce waste. Metal is available as a stock form in **sheet, rod, bar** and **tube**, and it is sold by length, width, thickness and diameter.

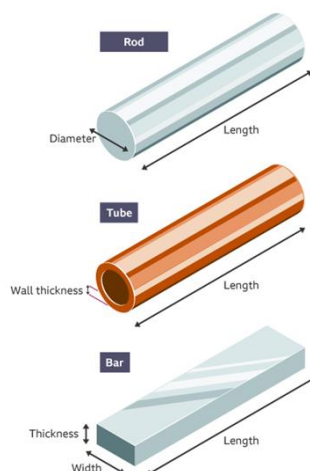

Steel rod is a solid round piece of metal, and the **diameter** and length are needed when ordering. Steel bar can come in many **cross sections**, such as square and rectangle, and the dimensions of the cross section and the length are needed when ordering.

Using **steel** as an example: the thickness of sheet steel is measured using a scale called '**standard wire gauge**' (**SWG**). Conversion tables allow the purchaser to understand SWG sizes in millimetres (mm), eg a 2 mm-thick piece of sheet steel has a SWG size of 14. When buying steel tube, the **wall thickness** is measured using the SWG scale and the outer diameter and length are needed when ordering.

When buying sheet metal, the SWG size gives the thickness measurement, but the length and width measurements are also needed. Bulk buying metal, as with most items, can save money.

Example:

1 m² aluminium at 3 mm thick (SWG 11) = £29.00 per m²

Twice the thickness would cost:

1 m² aluminium at 6 mm thick (SWG 4) = £44.00 per m²

The percentage increase in the cost for the thicker aluminium can be calculated:

Increase in cost = £44.00 - £30.00 = £14.00

This needs to be calculated as a **percentage** of the thicker aluminium:

$(14 \div 44) \times 100 = 32\%$

This shows that 100% more steel has been bought for just **32%** of the cost.

Question 14

If 1 m² steel at 2 mm thick (SWG 14) = £45.00 per m²

Twice the thickness would be:

1m² steel at 4mm thick (SWG 8) = £57.00 per m²

What is the percentage increase in the cost for the thicker steel?

Each material group has its own preferred set of standard components to fasten and join them together - metal is no exception. **Rivets**, nuts, bolts and screws are all common standard components to fix metal into place.

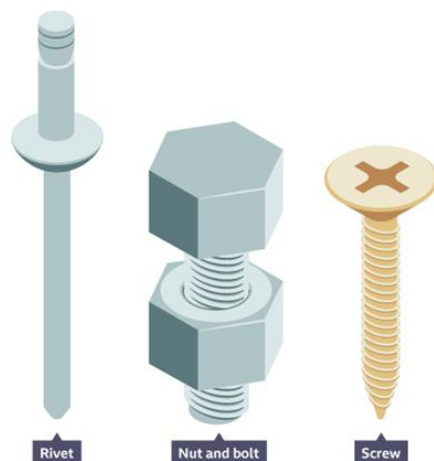

A rivet is often used to hold sheet material to another metal structure, eg some 'off-road' cars have their body held to the structure using a rivet. Nuts and bolts work by tightening a nut along a threaded bolt so that the sheet material is **compressed** in place. Screws work in a very similar way - as a screw is turned it drives deeper into one material as it compresses another in place.

Reinforcing and stiffening

Forces act on materials all the time - even if a material appears stationary it still has a force acting on it. There are five terms used to describe what type of force can act on a material:

- tension** - a pulling force
- compression** - a pushing force
- shear** - forces acting across the material
- electrical** - ability to conduct electricity
- magnetic** - magnets will attract metals that contain iron

Each metal type has different **properties** in relation to the way they react to each of the five forces. It is therefore important to know how to test a metal so the correct one can be chosen for the specific task.

Tension can be tested by pulling opposite ends of the metal. The **tensile strength** can be tested to see if the chosen metal will be fit for purpose by fixing a piece of metal to a point and then loading it with a pulling force.

Compression can be tested by applying a force on top of the piece of metal. If the metal compresses, then **reinforcing** the metal could be an option.

Often the shape of the metal plays a big part in how it will react to a force. A 'rolled steel joist' (RSJ) is used in construction work as the shape withstands bending and compression.



Rolled steel joist (RSJ)

Shear forces act in different directions and cut across a material, but a huge amount of force is needed to shear through a piece of metal. If a piece of metal is cut using **tin snips**, the cut will have been made by a shear force.



Tin snips

Electrical conductivity can be tested by making a simple circuit and passing a current through it. If the circuit is complete, then the current will pass through the material - in the example below passing through the paperclip, causing the bulb to light up.

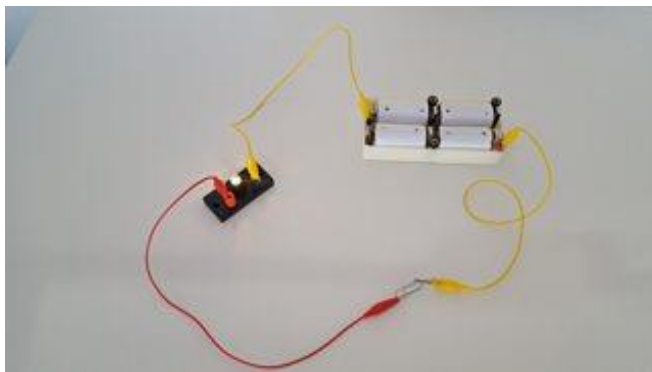

Magnetic materials can be tested through the use of a magnet. If the material is attracted to the magnet, then the material will be classed as magnetic.

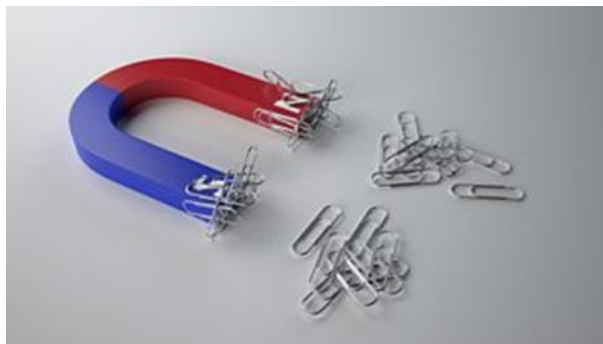

Production in quantity

There are four terms used to describe the scale of production in relation to manufacturing a product:

- **prototype** and one-off production
- **batch production**
- **mass production**
- **continuous production**

Prototypes and one-off production

There are many ways to produce a prototype - some are rough and look like models and others are well finished and function as intended. It is now possible to **3D print** metal, and many engineering companies have welcomed this technology as 3D printing is classed as **additive manufacture**, rather than subtractive. Additive manufacture builds up the metal form in layers, whereas **subtractive manufacture** takes material away from a larger piece. There is very little waste when using additive techniques, making it more environmentally friendly.

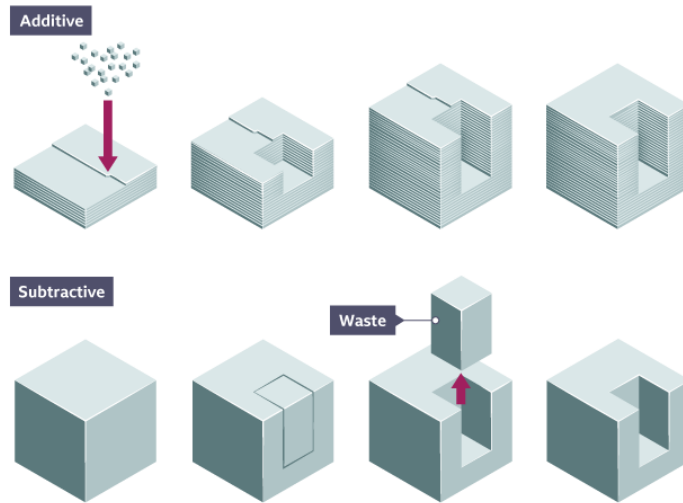

A custom-made or **bespoke** product that is made from metal could be made based on a customer **design specification**. Products such as rings and jewellery are often made personally for a customer and only one will ever exist.

Batch production

Batch production is where many items of the same product are produced, such as a bike frame or parts for a metal fence. Many metal products are joined by **welding**, often done by hand rather than by machines, and the metal is held in place with a **jig** during the manufacturing process. The jig ensures that each part stays in place whilst the welding is completed.



When a product is made in a batch, it is often far cheaper per product than when making just one.

Mass production

Mass-produced products are manufactured in large volumes, and often **assembly line** workers can be used to fit standard components, such as screws and **hinges**, to parts. Mass-produced metal products include door handles, barbecues and cooking utensils.

Continuous production

Continuous production takes place 24 hours a day, 7 days a week and, in some cases, 365 days a year. Many cars are made using a continuous production process, and the huge amount of sheet steel that is bought for this brings down the prices.

When cars are made using continuous production methods, most of the work in the factory is automated using robots, with **sheet** steel being cut and pressed, transported, welded and painted by them. However, people are needed to work alongside the robots to fit parts to the cars, as robots currently lack manual **dexterity**



Accuracy

Unlike metal, materials such as timber, paper and board change shape easily depending on temperature or the amount of moisture they are holding. Metal can change shape and expand in the heat, but it is not prone to the same amount of movement as timber is. It is often the case that engineers can work to a fine **tolerance** when using metal.

Digital micrometers can be used to measure the width of a material and **digital vernier calipers** can be used to measure the outside width, inside dimensions and depth of holes. Both tools measure to 1/100th of 1 millimetre (mm) and can be read quickly because of the digital screen.



Digital micrometer

Quality control

Quality control takes place during the manufacture of any product, but, since metal parts are engineered to a fine tolerance, there are specific quality control tools to ensure that metal parts have been made correctly - one such tool is called a '**go-no-go gauge**'. The 'go-no-go gauge' has a 'go' side and a 'no-go' side - when testing the product one side must pass and one side must fail.

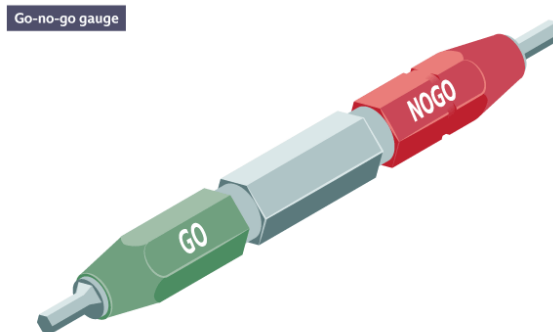

Example

It is common to hear engineers say they can work to a tolerance of 'one thou', meaning 1/1,000th of an inch.

$$1 \text{ inch} = 2.54 \text{ mm}$$

$$2.54 \div 1,000 = 0.0254 \text{ mm, so:}$$

'one thou' = 0.03 mm (to 2 decimal places)

If an engineer was asked to mill a 50-mm slot in a block of **aluminium** to the tolerance above, it would be possible to check whether the slot was correct by using a 'go-no-go gauge':

$$50 \text{ mm} - 0.03 \text{ mm} = 49.97 \text{ mm}$$

This side of the gauge must be able to slide into the milled slot.

$$50 \text{ mm} + 0.03 \text{ mm} = 50.03 \text{ mm}$$

This side of the gauge must **not** be able to slide into the milled slot.

Question 15

If 1 m lengths of steel bar were cut +/- 5%, what would the range of tolerance be?

Shaping

Metal is a popular material to use in schools within Design and Technology lessons as it is generally not too expensive in comparison with other materials that are available.

There are many different tools for marking out on metal:

- **scriber** - a sharp point to put a fine scratch on the surface of the metal that is being marked
- **steel rule** - more accurate than a plastic ruler and often has half millimetres as well as millimetres
- **ball pein hammer** - used for tapping a centre punch before drilling a hole
- **centre punch** - used to create a drill point before a hole is drilled into metal so that the drill bit does not slip on the surface

•**engineer's square** - used for marking out at 90° to an edge or face

•**marking blue** or **layout fluid** - dye used to coat the surface to be marked, and if it is hard to see the line made with a scribe then it will be easier to scratch a fine line through the blue dye



Scribe.

A **hacksaw** is normally used to cut metal by hand. If a smaller piece of metal is being cut, then a junior hacksaw can be used. Once the metal is cut close to a marked line, a **file** can be used to remove material up to the desired line. Files can be bought in different shapes, sizes and cutting grades - a rough-cut file can remove metal faster than a smooth-cut file and should always be used first.



A junior hacksaw has a smaller blade used for more precise cutting

Once filing has been done and the profile of the metal is at the desired shape, the file marks can be removed with abrasive papers such as **emery cloth** and **silicon carbide paper** (often called '**wet and dry**' paper as it can be used both wet and dry). A buffing machine can be used to polish the metal to achieve a mirror-like finish.



Buffing machine

Metal can also be drilled by using a variety of different drill bits, which work by twisting into a piece of metal:

- twist drills - used to simply drill a hole of fixed diameter into a piece of metal
- countersink bits - used to profile a hole so that a screw can sit flush with a surface

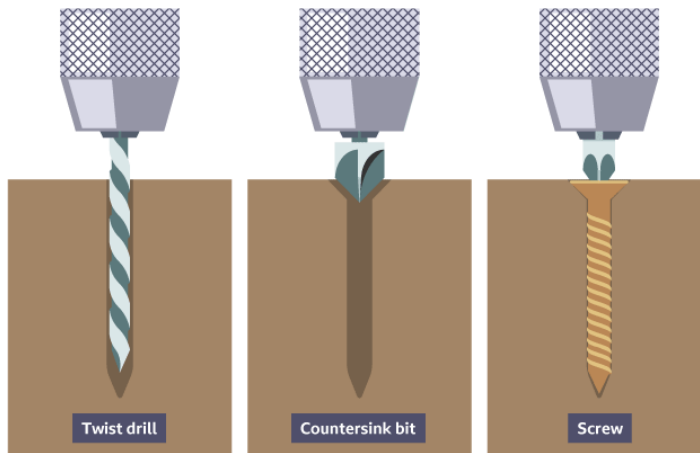

Fabricating

There are three main methods of shaping metal by a machine in a **commercial** setting:

- Turning
- Milling
- casting



CNC lathe

Metal can be turned in a **lathe**, which can be hand operated or controlled via a computer on a **computer numerical controlled (CNC)** lathe. A lathe spins the work at high speed as a cutting tool is introduced to the metal to produce round and cylindrical shapes. Round pieces of metal are held in a lathe using a three-jaw chuck, and metal that is not round is held by a four-jaw chuck.

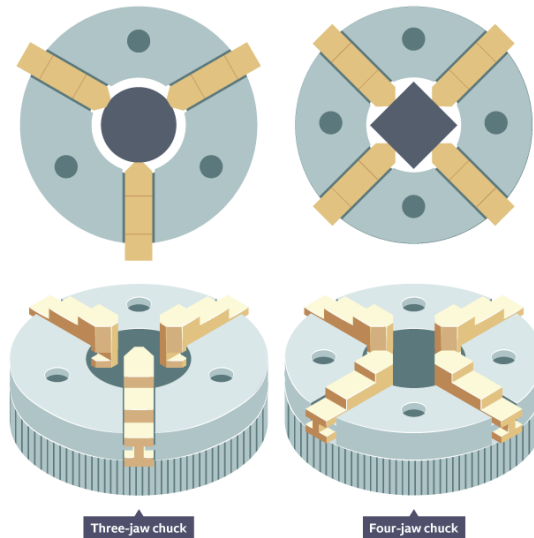

Metal can be shaped using a **milling machine** - a very versatile tool for smoothing a surface or edge and for cutting grooves and profiles. Milling machines can work either horizontally (horizontal milling machine) or vertically (vertical milling machine) - both machines perform the same tasks; the main difference is the direction the cutting tool is held.



If a part is too complex to shape by hand or on a milling machine, it can be **cast** by melting metal and then pouring it into a mould. It is possible to cast **pewter** quite easily in schools. The melting point is low, around 200°C, and moulds can be made from laser-cut or hand-shaped **medium-density fibreboard (MDF)**.

Sand casting can be used to cast larger and more complex shapes as it uses a two-part mould:

1. a **former** is made, usually by hand, and is placed in the '**green**' **sand**, which is packed tightly around the former before it is removed
2. this is repeated on the other part of the mould
3. two holes are made in the sand, one for the molten metal to be poured into (the runner) and one for the metal to come up and out the other side (the riser)
4. once they are both ready, parting powder is applied to the sand and the two moulds are placed together, one on top of the other
5. the molten metal, often **aluminium** in schools, is poured into the runner until it comes up to the riser when the cavity in the sand is full of metal

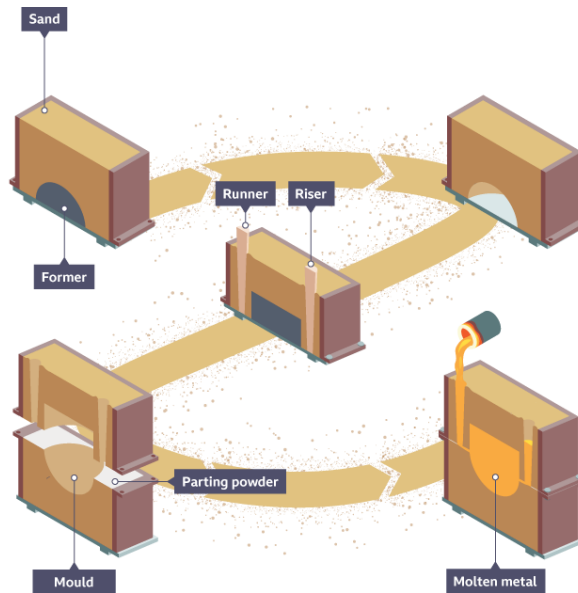

Assembling

There are many different joining methods for fixing metal in place. Non-permanent methods include nuts and bolts, screws and **rivets**. Whilst many would consider a rivet a permanent method of joining, it is possible to drill out an old rivet so that a new one can be used. Permanent methods of joining metals are listed in the table below:

Soft soldering	Used to solder printed circuit boards (PCBs) and electronic components. Plumbing application where copper pipes are joined together.
Brazing	Used for joining steel by melting a brass rod on the hot steel. As the brass melts, it forms a joint. Brazing is a slow and safe way to learn about joining metal with heat.
Gas welding/Oxyacetylene welding	Oxygen and acetylene are used to produce a flame with a temperature of over 3,000°C. A filler rod is melted so that pieces of metal can be joined together. Gas welding/Oxyacetylene welding is faster than brazing and can also be used to cut metal.
Arc welding	Heat is produced by a high current that is passed down the filler rod. When the filler rod melts, it fuses the pieces of metal together. Arc welding is fast and portable.



Soft soldering electronic components

Surface finishes

As with most materials, surface preparation is important before applying a **finish**. Oil and grease need to be removed before **painting**, and dents and scratches need to be filled and rubbed down with **emery cloth** or **silicon carbide paper**.

Paint is a common finish applied to bare metal surfaces. Once the surface is smooth the painting process can start, very much like painting timber:

- 1.a basecoat or primer is applied first, which will show blemishes that would only stand out more with paint
- 2.rubbing down again before painting is important
- 3.once the primer coat is perfect, a layer of paint can be brushed or sprayed on
- 4.layers can be built up until the colour is even
- 5.a final **lacquer coat** can be added so that the paint is protected, and the final finish is shiny

Painted playground equipment



Dip coating is a popular finish for the handles of many tools and coat hooks. It is a straightforward process:

- 1.a piece of metal is heated up to around 250°C
- 2.once hot, it is then dipped into a **polyethylene** in powder form
- 3.this has air blown through it so an even coating of the powder is dusted onto the hot metal, resulting in a smooth and shiny coating on the dipped metal

Polyethylene is available in many colours and can help improve grip when applied to tool handles.

Powder coating is a method of attracting paint in a powder form towards an electrically charged object:

- 1.paint that is in powder form is sprayed from a paint gun
- 2.the paint is attracted to the electrically charged object
- 3.a fine and even coat of powdered paint covers the surface of the product and, once heated, the powder melts and produces a 'run free' paint finish

Powder coating



Lacquering is a method of applying a clear varnish that prevents the metal rusting or oxidising while allowing the natural finish of the metal to be on show. It is a straightforward process:

- 1.the surface is cleaned and polished so it is free of imperfections
- 2.a varnish is sprayed onto the surface
- 3.the varnish is cured using UV light

Some metal products that are made from **steel**, such as watering cans and lamp posts, would **rust** if they were not protected. A common process that is used to protect such products is **galvanising**. Steel products are given a zinc coating by dipping them into the molten **zinc**. For example, corrugated steel roofs of farm buildings and sheds are often made from steel that has been galvanised. After a few decades, the galvanised coating will wear because of acid in the rain and the steel will start to rust, so the roof will need replacing one day.

MATERIALS
TIMBERS
For Timber
Students Only

Timbers

Hardwood and softwood are types of timber that come from many different trees. Manufactured boards such as MDF and plywood are man-made.

Sources and origins

Natural timbers

Hardwoods

Hardwood comes from **deciduous** trees with broad leaves. Hardwood trees take a long time to grow, around 60 years (sometimes up to 100). This means that they are rarely planted and very expensive. The majority of hardwoods grow in **tropical** regions, such as Amazonian climates, while others grow in **temperate climates** such as Europe. Their **growth rings** are much smaller than softwood, making the **grain** closer. Examples include:

- Beech
- Mahogany
- Oak
- Balsa
- Jelutong**
- Birch
- Ash

Hardwood	Physical properties	Working properties
Beech	Slight pink tint, close grain	Tough, durable and smooth to finish
Mahogany	Dark-reddish colour, very close grain	Cuts and polishes easily, gives a fine finish, used for high-quality furniture
Oak	Moderate-brown colour with unique and attractive grain markings	Tough and durable, polishes well, used for quality furniture
Balsa	Pale and wide-spaced grain due to it being a fast-growing hardwood	Very soft and easy to form, often used to make models

Jelutong is used for model making and **vacuum forming** moulds, and it is selected because it is easy to cut and shape. It has a close and even grain but, because it is soft, it is not good for structural uses.

Jelutong



Birch is often used for veneers in furniture and it is selected because of its even grain. Like jelutong, it is easy to cut and shape but it is also liable to rot and insect attacks.

Birch



Ash is used in ladders, tool handles, walking sticks and sports equipment, such as oars. It finishes well and it is selected because it is strong and flexible but, like birch, it is liable to rot and insect attacks.

Ash



Softwoods

Softwood comes from **coniferous** trees with needle-like leaves that normally stay on during the winter - larch is an exception as it loses its needle-like leaves during the winter. Softwoods naturally grow in colder regions such as Alpine climates. Softwood trees grow quickly so their growth rings are wider making the grain wider. This ability to grow quickly means that softwood trees can be used for timber after 20-30 years - making them cheaper than hardwood. They are often grown commercially, and examples include:

- Pine
- Cedar
- Larch

Softwood	Physical properties	Working properties
Pine	Pale coloured with aesthetically pleasing grain	Lightweight, easy to form, used for construction and decking
Cedar	Lightweight, pale colour with even texture	More expensive than pine but not as strong

Larch is used in exterior cladding, small boats and for fence posts and is selected because it is durable and resistant to water. It is, however, more expensive than other softwoods.

Larch



Manufactured timbers

Manufactured timbers can be made from leftover wood such as sawdust and wood chippings. This means they can be made into large sheets rather than being restricted to the size of a tree trunk. They are much cheaper than both hardwoods and softwoods and are often used in low-cost furniture. Examples include:

- medium-density fibreboard (MDF)
- Plywood
- Chipboard

Manufactured timber	Physical properties	Working properties
Medium-density fibreboard (MDF) - used for general carpentry work and flat-pack furniture as a veneer can be applied or it can be painted	Smooth, light brown, can be veneered	Smooth and easy to finish, absorbs moisture so not suitable for outdoor use
Plywood - used for furniture, shelving, construction and toys	Layers of veneer glued at 90 degree angles for strength, aesthetically pleasing outer layer	Easy to cut and finish, can be stained or painted

Chipboard is commonly used in kitchen worktops and flat-pack furniture and is selected because it is inexpensive to produce as it is made from waste timber. Chipboard is commonly covered using a real wood veneer or melamine sheet so it is not on show. Covering the chipboard provides a layer of protection - if chipboard is exposed to moisture it will swell up and fall apart.

Chipboard



Characteristics and properties

Due to the way that trees grow, natural timbers have very similar physical characteristics.

Knots

A **knot** in timber marks where a branch once grew out on the tree. Knots often fall out from **planks** as they shrink, leaving a hole. It is preferable to use timber without knots, unless for a decorative purpose.



Colour

Different trees produce timbers that have different colours, eg the pale-yellow hue of pine and the reddish-brown of mahogany.

Pine



The colour of timber from the same type of tree can vary, making each plank of timber unique. The [colour of planks can be altered](#) using **wax**, **varnishes**, **stains** and **paints**.

Grain structure and density

Both **hardwoods** and **softwoods** produce a new layer under their bark each year called **growth rings**. These are close together for hardwoods and further apart for softwoods.



Hardwoods have two types of long **vessels** that run the length of the tree:

- Fibres
- Pores

Working properties

There are many terms that can be used to [describe the properties of materials](#) such as hardness, toughness and **durability**. Other terms include:

- Elasticity** - The ability of a material to stretch and return to its original shape. Timbers are generally not very elastic, although some are a little more than others, eg yew is used for making bows in archery.
- Tensile strength** - The ability of a material to withstand being pulled by a certain amount of force. Timbers have higher tensile strength than compressive strength.
- Compressive strength** - The ability of a material to withstand being crushed by a certain amount of force. The denser the timber, the greater the compressive strength, eg oak has a higher compressive strength than balsa.

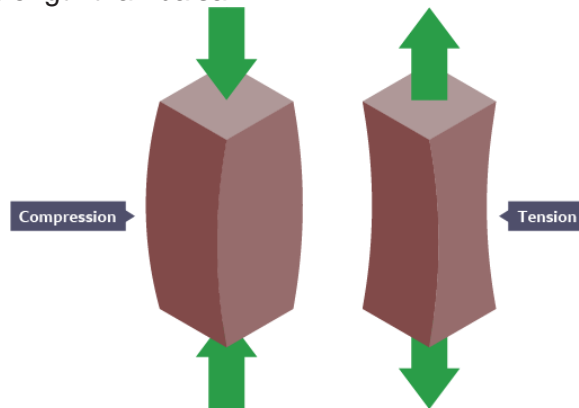

Social and ecological issues

When considering the ecological and social implications of using timber, the term '**deforestation**' is often used. Deforestation is when a **clearing** is made by chopping down trees. This can often bring jobs and money into a local area but can also push out communities and wildlife. Without responsible management of deforestation, accompanying environmental issues can occur, such as:

- soil **erosion** that can lead to landslides
- an increase in global warming

If more trees are planted than are cut, it is possible to minimise the environmental impact. Hardwood trees take a long time to grow in comparison to softwood trees so are more commonly planted in managed forests.

Supply and demand can cause issues for forest management. If the customer demands more timber due to an increase in purchasing, a forest management organisation could struggle as trees will take time to mature. **Trend forecasting** is when manufacturers and retailers try to predict the trends or fashions over the following years so that they can design and make products that people will want in the future. For example, timbers have become popular in the external cladding of many buildings, and therefore there has been an increase in demand for timber.

Alternative boards made from recycled timber are available.



Plywood, medium-density fibreboard (MDF), chipboard and blockboard can all be made from recycled timber. These **recycled** materials are made by gluing pieces of timber or fibres of timber together - the gluing process makes it very difficult to recycle the timber a second time around. MDF cannot be recycled and often ends up in a landfill site when it has reached the end of its life.

Trees are good for the environment as they absorb carbon dioxide and release oxygen, and managed deforestation aims to balance this. However, the environment can also be polluted through the supply and demand of timbers:

- transportation often involves burning **fossil fuels**, adding to the **carbon footprint** of the timber
- wastage of small branches and leaves are often burned, releasing carbon dioxide
- processes such as **kiln drying** use energy, adding to the **ecological footprint** of the timber

Whenever environmental impact is to be reduced, the term 'the 6 Rs' can always be called upon to ensure an in-depth analysis has been done. The 6 Rs can be considered by the designer, the **manufacturer** and the **consumer** to reduce the negative impact on the environment.



Here are some questions to prompt 6 Rs thinking:

- Reduce** - Can the amount of timber used be reduced? Can the timber be bought locally to reduce product miles?
- Reuse** - Can the timber be reused for another purpose once a product is finished with?
- Recycle** - Can the timber be disposed of correctly so that it can be recycled to produce another material like chipboard or MDF?
- Rethink** - Can the way a product is made be redesigned so that less timber is used?
- Refuse** - Refusing to use hardwood can be a consideration; could a wood stain be used on softwood instead?
- Repair** - When a product is broken, can it be repaired rather than discarded?

Selecting timbers

Materials can be selected based upon their **working properties**. It is important to know and understand which materials can be used for a specific purpose:

- How do they look?
- What are they commonly used for?
- How can they be manufactured?
- How do they perform in use?
- What makes them unique - are they the most **durable**, the lightest etc?

When selecting a timber-based material, there are many different types to choose from. **Hardwood** and **softwood** are types of timber that come from many different trees. Manufactured boards such as **medium-density fibreboard (MDF)** are man-made from **recycled** material, and other boards such as **plywood** are man-made from layers of wood.

Aesthetics

Aesthetics relate to the way a material looks, and each example of timber has a different pattern on the grain, texture and colour. The way a timber looks can be [altered through several methods](#), including:

- Staining
- Varnishing
- Oiling
- Waxing
- Painting
- Laminating

Quite often medium-density fibreboard (MDF) is laminated with a single sheet of a hardwood **veneer** to give the impression that solid hardwood has been used to make a product, but at a fraction of the cost.

Environmental factors

Sustainability

When a tree is chopped down for timber, there is a cost to the environment. Trees are vital as they absorb carbon dioxide (CO₂). Although more than one tree can be planted in the place of each tree that is chopped down, older trees often absorb more carbon dioxide and provide more of a habitat for wildlife because of their size.

Timber from [sustainable forests](#) is an important consideration too. Some softwoods are readily available because of the fast-growing nature of the tree. Hardwoods, on the other hand, grow considerably slower and are therefore much more expensive.

Genetic engineering

Genetic engineering into the DNA of trees is being explored by scientists to develop trees that could grow faster or have a resistance to particular diseases. The long-term effects of genetic engineering are unknown, which causes some people to be wary of using it.

Seasoning

When a tree is initially cut it is extremely wet, with 85 per cent water content. The timber is often dried to 10-12 per cent for indoor use through a process called **seasoning**. Seasoning increases strength, stability and resistance to decay. There are two types of seasoning:

- air seasoning - leaving the planks outside for a few years till they are 18% water
- kiln drying - pumping steam and warm dry air around the planks till they are 10% water

A designer should select timbers that have been suitably seasoned for their intended use. For example, furniture to be used in warm, dry and centrally heated houses will need to be kiln dried.

Upcycling

Timber products can be revamped by being repaired, painted and adapted into new products. For example, old pallets are sometimes reused in gardens.



Availability factors

Use of stock materials

Timber is processed and sold in standard sizes. Using the standard sizes in designs reduces the time needed to change the raw materials, by cutting the wood into smaller sizes or joining pieces to make larger sizes.

Use of specialist materials

Timbers can be treated for specific purposes, for example:

- **polymerveneers** can be laminated onto chipboard for kitchens to give the impression that a more expensive material has been used
- flame-retardant chemicals can be sprayed onto timbers used within house constructions to slow the spread of fire

Hurricanes, storms and disease

Naturally occurring events such as hurricanes and storms can blow trees over and these can then take many years to grow again. Also diseases, which sometimes arrive with imported products, can kill trees and can often spread rapidly through forests.

Cost factors

Material costs are an important factor when selecting a material. It is often possible that more than one material is suitable for a job but the quality of the material may vary; this alongside the associated manufacturing and treatment costs will determine which material is used.

Manufactured boards vary in price depending on where they are bought and how many are bought at once. Some timber is sold at a price calculated by **volume**. The price per metre cubed (m^3) is the method of working out the value. If the price per m^3 is known, then the calculation to work out the cost starts with working out the volume of timber that is needed.

Example

A piece of oak costs £1,700 per m³ and the piece to be valued is 1,000 mm × 50 mm × 250 mm. Calculate the price.

Convert to metres (m):

$$1,000 \text{ mm} = 1 \text{ m}$$

$$50 \text{ mm} = 0.05 \text{ m}$$

$$250 \text{ mm} = 0.25 \text{ m}$$

Work out the volume needed (m³):

Volume of a cube = length × width × height

$$\text{Volume} = 1 \text{ m} \times 0.05 \text{ m} \times 0.25 \text{ m}$$

$$= 0.0125 \text{ m}^3$$

Work out total cost (£):

$$\text{Total cost} = \text{volume in m}^3 \times \text{cost for 1 m}^3$$

$$= 0.0125 \times 1,700 = 21.25$$

$$\text{Total cost} = \text{£}21.25$$

Question 16

A plank of ash will be used in the design of a guitar body. It costs £1,850.00 per m³ and the neck design requires 650 mm × 60 mm × 55 mm.

Calculate the cost of the neck section.

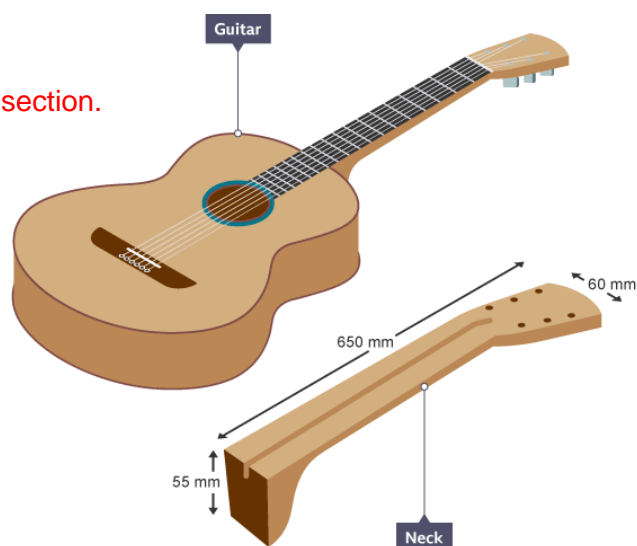

Social factors

Many social factors can affect choices made by customers, including:

- personal preferences
- Age
- Background
- Finances
- Interests

Products are often designed for a select social group. For example, flat-pack furniture tends to be designed for the mass market using materials which have a lower cost, eg medium-density fibreboard (MDF) and chipboard. It tends to be functional and follows the latest trends. Alternatively, bespoke furniture products often have a bigger budget, and costs can be added through labour and material choices.

Flat-pack furniture



Trends and popularity

Trends, fashions and popularity will change, which will consequently affect the selection of timber. Current trends may not be popular in a few years' time. In a consumer society, where some people can afford to buy products to keep up with trends and fashions, this can have an adverse effect on the environment by using up too many resources. Some manufacturers design products that deliberately fail after a certain time so that consumers buy new products - this is known as **built-in product obsolescence**.

All designers need to know the **stock sizes** that timber and man-made boards are available in. If stock sizes are known, then designs can be manufactured more economically to reduce waste. Once timber has been cut at a sawmill, it is referred to as '**rough cut**', with uses including garden fence posts and some building work. Timber that is sold at DIY shops or from a timber merchant can often be bought with smooth, **planed** edges.

If planed timber is bought, the price will be higher because of the care taken to process the length of wood. PSE is a term used to indicate that the timber has a '**planed square edge**'. This means that one edge will be planed smooth. PAR is a term used to indicate that the timber is **planed all round**, meaning that both the edges and sides have been planed. Planed timber is used for interior work where the timber is likely to be seen.

Hardwood and softwood are normally sold in lengths called:

- regular sections
- Mouldings
- Dowels
- Sheets

Regular sections and sheets refer to the proportional dimensions of the timber, whereas moulding refers to a decorative pattern that has been cut using a **spindle moulder**. Moulded timber can be used for skirting boards and dado rails. Dowels have a round **cross section** that is available in different **diameters**.



Regular sections

Manufactured boards are usually sold in standard sized sheets of 2,440 mm × 1,220 mm. However, these are often too large for customers to transport, so part sheets can be sold, such as 1,220 mm × 6,10mm (half the size).

Example

An internal shop sign has the following dimensions:

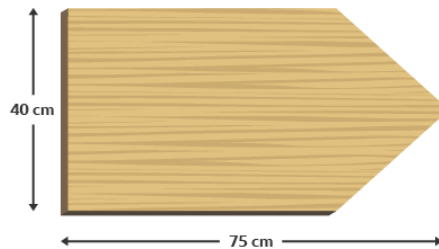

Calculate how many can be cut out of a 2,440 mm × 1,220 mm sheet of MDF.

Convert sheet to centimetres:

$$2,440 \text{ mm} = 244 \text{ cm}$$

$$1,220 \text{ mm} = 122 \text{ cm}$$

Work out how many can fit horizontally:

$$244 \div 75 = 3.253 \text{ or } 3 \text{ whole signs}$$

Work out how many can fit vertically:

$$122 \div 40 = 3.05 \text{ or } 3 \text{ whole signs}$$

$$3 \times 3 = 9$$

Therefore, **9 whole signs** can be made from 1 sheet.

Alternatively, the areas can be calculated and compared:

$$\text{Area of sheet} = 244 \text{ cm} \times 122 \text{ cm} = 29,768 \text{ cm}^2$$

$$\text{Area of sign} = 40 \text{ cm} \times 75 \text{ cm} = 3,000 \text{ cm}^2$$

$$29,768 \div 3,000 = 9.9226 \text{ or } \mathbf{9 \text{ whole signs}}$$

Question 17

A medium-density fibreboard (MDF) plaque has the following measurements:



Calculate how many can be cut out of a 1,220 mm x 610 mm sheet of MDF.

Reinforcing and stiffening

Forces act on materials all of the time - even if a material appears stationary it still has a force acting on it.

There are three terms used to describe what type of force can act on a material:

- **tension** - a pulling force
- **compression** - a pushing force
- **shear** - forces acting across the material

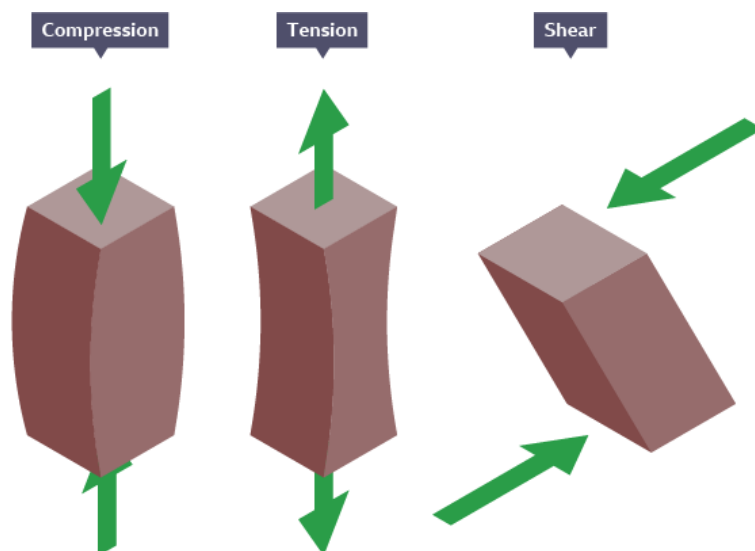

Timber has good **tensile strength** and compressive strength because of its fibrous structure. Timber, if untreated, does not have good bending qualities and often snaps when bent. If a piece of timber has to be bent to shape, there are a few options to help prevent it from snapping. If timber is soaked in water or exposed to steam, it can become more flexible. Slots can be cut along the inside face of the timber to be bent allowing for the inside face to cope with the compressive force - this is called **kerfing**.

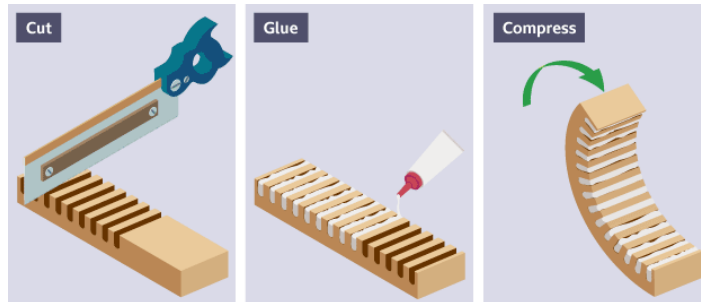

Frame structures

A square or rectangle is a commonly used shape for products, but it is not very strong and can easily turn into a diamond shape through **torsion** forces. A rectangle of timber can be strengthened by one, or a mixture, of the following:

- putting a thick panel inside the frame
- adding a diagonal **strut** or triangle across each of the corners
- adding a strut from corner to corner



Struts are also used within the construction of timber-framed buildings to add strength to the structure

Lamination

A **laminated** timber consists of two or more layers. Plywood is strengthened by having each layer of timber glued at right angles to each other.

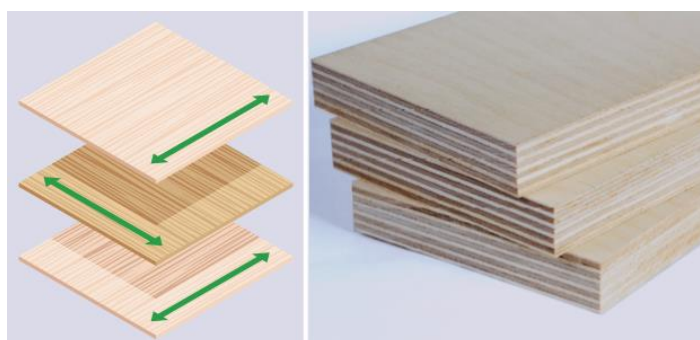

Timber is easier to bend along the grain, but when another sheet of timber is glued at right angles it becomes hard to bend in any direction because the grains are at right angles to each other. As the plywood becomes thicker, the less likely it is to flex at all. This is referred to as **high cross-sectional stability** and is a desirable feature.

Braces and tie bars

A brace is similar to a strut; it is a bar that is added to strengthen a material or product. They usually go diagonally across a material to make triangle shapes. A tie bar is used in a similar manner and holds the frame in shape. While a strut resists compression, a tie bar resists tension. In construction, a tie bar sits across the structure where the roof meets the walls and acts to resist the weight of the roof.

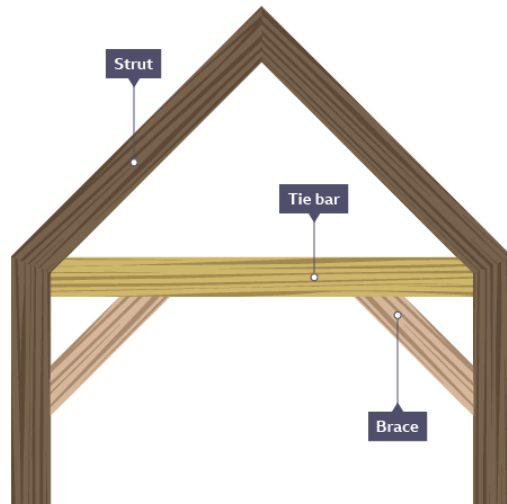

Embedding composite materials

Timbers can be combined with other materials, such as metal and **composites**, combining the properties of these materials. For example, in construction, timber and steel connectors are used to take advantage of the natural strength and appearance of the wood as well as the strength and durability of steel.

Production in quantity

There are many different processes used to cut and shape timbers in quantity:

Routing

A router can be hand-held, mounted to a table or even computer controlled. All routers work by rotating a cutting bit at high speed. As the cutting tool passes over or along the edge of the timber, a cut or profiled shape is made. Routers can plunge into a material to cut holes. They can follow **jigs** or **patterns**, for example kitchen fitters might follow a pattern to join worktops together.

Hand-held router



Sawing

Sawing machines help cut timbers quickly. The circular saw and bandsaw are commonly found in workshops.

Mortiser

A mortiser makes a square hole for a mortise and tenon joint.

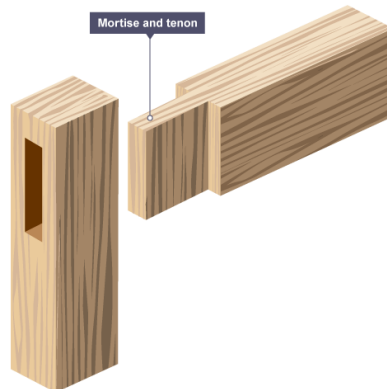

Bag press

A **bag press** is often used to create curved shapes in laminated timber **veneers**. The bag is sealed and the air is sucked out while the glue dries between the veneers.

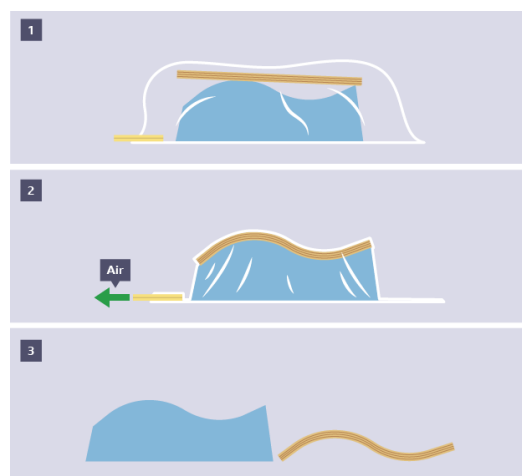

Scales of production

There are four terms used to describe the scale of production in relation to manufacturing a product:

- **prototypes** or one-off production
- **batch production**
- **mass production**
- **continuous production**

Prototypes and one-off production

There are many ways to produce a prototype - some are rough and look like models, and some function as intended and are well finished. Many architectural models are made from timber lolly sticks, matches or balsa wood. Model-making timber can be shaped easily and glued in place at speed.



A custom-made or bespoke product that is made from timber could be based on a customer **design specification**. Products such as made-to-measure wardrobes or hand-crafted furniture are expensive because each piece of material has been designed and cut for that specific product, involving great skill and time.

Batch production

Batch production is where many items of the same product are produced. An example relating to timber is where a set of chairs is required to match a dining room set.

A **carpenter** could design the chair, and then cut all the timber at the same time to make the set. The carpenter would then have a kit to start making batches of chairs. If each part of the chair needed to be drilled in exactly the same place, the carpenter would make a drilling **jig** that would hold the timber while each part was drilled. If a part of the chair needed the same shape **profile** from a plank of timber, the carpenter would make a **designing template** so that each part would be shaped the same.

Each time a product is made, the materials that are used have had to be bought. If just one product is made, quite often the cost is high because small orders are placed to supply the materials. When a product is built on a large scale, money is saved when compared with the cost of making a one-off product.

Mass production

Mass-produced products are manufactured in large volumes, often on **assembly lines** where workers fit standard components such as screws and hinges to parts. Examples of mass-produced timber products are **mouldings**, doors and pencils.

Continuous production

Continuous production takes place 24 hours a day, 7 days a week and, in some cases, 365 days a year. There is not generally the demand for a timber-based product to be made using continuous production, but stock sizes of timber and paper can be produced using continuous production methods.

Techniques for quantity production

There are many techniques used for quantity production of timber to ensure that products are made efficiently and of a similar quality. For example, **marking out** helps to ensure the timber is measured accurately and will be cut to the correct size repeatedly. Another example is the use of **templates** made from card or thin sheet metal, which make cutting the same shape repeatedly quicker, more efficient and more accurate.

Marking out methods

Transferring measurements onto a material is especially important for one-off production. For batch and mass production the machinery is often set up to process the materials automatically. In one-off production, it is important to start with a square edge so that the measurements can be made from these edges. This can be achieved using a set square.

A set square



Other aids include:

- **jigs** - used to guide a drill or saw to cut in exactly the same place each time on every piece of timber - reduces marking out time thus increasing the efficiency of the manufacturing process

- **fixtures** - holds the piece of timber in place whilst it is being worked on

- **templates** - made out of paper, card, thin metal or wood, these are drawn around to mark out the same shape repetitively, with the aim of speeding up the marking-out process and decreasing the chance of an error occurring

- **patterns** - a collection of templates that go together to make a part, or all, of a product

Sub-assembly

A sub-assembly is a series of components that, when assembled, form a part of a product. For example, a wooden knob turned on a wood lathe may be bought pre-made to add to a piece of furniture or to a door. This saves manufacture and assembly time and means that additional machinery, such as a lathe, does not have to be bought and operated.

Computer aided manufacture (CAM)

A product can be drawn on a **computer aided design (CAD)** package and then sent to a **computer aided manufacture (CAM)** machine to be cut out, eg using a laser cutter. This has a high initial cost so is often used in mass production.

CAD

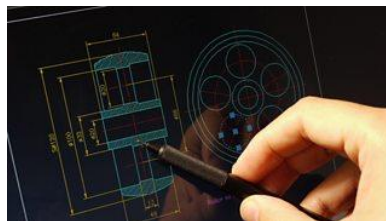

Efficient cutting to minimise waste

Materials cost money so it is important to minimise waste. When marking out shapes on timber, it is important to make them as close together as possible to reduce any material waste.

Accuracy and quality control

When working with timber, it is important to remember that it is a natural material that changes shape as different amounts of water are absorbed by it. It can warp and twist at different times of the year depending on how dry or wet it is. For example, if a timber door for a shed is made to be a tight fit in the dry summer months, it is likely that the door will be too tight to open when it is wet or damp in the winter.

Working within a tolerance

When making something from timber, **digital vernier calipers** are often used to measure to 1/100th of 1 mm.



Digital vernier caliper

When working with timber, a tape measure can be used to measure a correct length to 1 mm. This **tolerance** is acceptable due to the nature of the material and the fact that it will change shape at some point while being used.

Example

If a length of timber is measured with a tape measure, it could be written that the timber is 1,000mm +/- 1mm. This indicates that the timber could be 999 mm or 1,001 mm.

$$1,000 \text{ mm} + 1 \text{ mm} = 1,001 \text{ mm}$$

$$1,000 \text{ mm} - 1 \text{ mm} = 999 \text{ mm}$$

The range of possible sizes is anywhere between 999 mm and 1,001 mm. This means that some lengths might be 2 mm bigger than others.

If the tolerance was +/- 2 mm:

$$1,000 \text{ mm} + 2 \text{ mm} = 1,002 \text{ mm}$$

$$1,000 \text{ mm} - 2 \text{ mm} = 998 \text{ mm}$$

The range of possible sizes is anywhere between 998 mm and 1,002 mm and some lengths might be 4 mm bigger than others.

Question 18

A 1 m length of planed all round (PAR) ash needs to be cut with a tolerance of +/- 1%.

What would the range of tolerance be?

Shaping

There is a variety of equipment and processes used with timber, for example:

- hand tools for marking out, cutting and shaping, eg **engineer's square** for marking lines at 90° to an edge
- machinery, eg [circular saws and bandsaws](#)
- digital design and manufacture, eg laser cutters and **computer numerical controlled (CNC) routers**

Cutting

There are a great many saws used to cut timber - some suit long straight cuts on thicker planks, and others suit curves and complex shapes:

- rip saw - for 'ripping' through and rough cutting thicker planks and boards
- tenon saw - for cutting straight lines with accuracy
- coping saws, jig saws and scroll saws - all for cutting thinner pieces of timber, and can cope with curves too

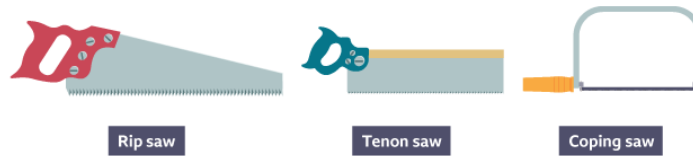

Shaping

Timber can also be drilled by using a variety of different drill bits, which work by twisting into a piece of timber:

- twist drills - used to simply drill a hole of a fixed **diameter** into a piece of timber
- countersink bits - used to profile a hole so that the top of a screw can sit flush with a surface
- forstner bits - used to drill flat-bottomed holes
- hole saws - used to cut '

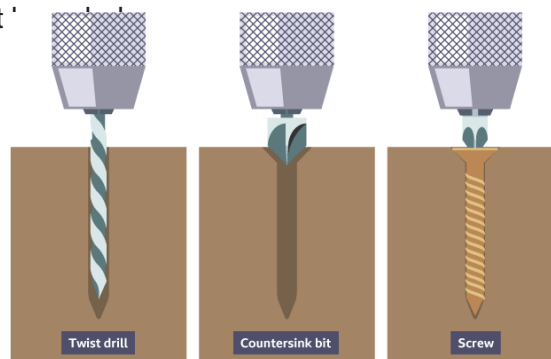

As well as cutting and drilling, there are other skills to develop to shape timber:

- chiselling** - used to remove timber, usually up to a cut or between two cuts, eg in the production of wooden joints such as dovetails
- planing** - used to smooth the edge of a piece of timber by running a sharp blade in the direction of the grain, or can be used at an angle to produce a chamfered edge
- abrading** or **sanding** - used to achieve a profiled shape or smooth surface finish by removing fine particles, normally the final stage in shaping the timber and done by hand or with a machine (belt, disc or orbital)
- hand sanding, using:
 - abrasive paper such as sand or glass paper
 - files
 - **rasps** - have larger teeth than a file that can leave marks in the wood
 - **surforms** - similar to a cheese grater in appearance, used for rough shaping but again leaves marks in the wood



Rasps

Turning

A **lathe** works by spinning a piece of timber at speed. While the timber is turning, a wood-turning tool is pushed into the timber to change its shape. Some timber can be held in place by compressing it from end to end. This would allow a **spindle** or cylinder to be shaped. Another way to hold the timber in place is to screw it to a faceplate - the timber then spins on the lathe, and this would allow a bowl to be turned.



Turning a spindle on a lathe

Carving

Wood carving uses chisels to cut away at the wood and produces a piece of artwork. It has been mostly replaced by CNC machinery because of its labour-intensive nature.



Fabricating

Fabricating involves joining, cutting and shaping materials so that a product can be made. Timbers are used to produce a variety of products and can be joined in many ways.

Lamination

A **laminate** is a thin layer of material. **Plywood** is strengthened by having the timber glued at right angles to each other. Timber is easier to bend along the grain, but when another sheet of timber is glued at right angles it becomes hard to bend in any direction because the grains are at right angles to each other. As the plywood becomes thicker, the less likely it is to flex at all. This is referred to as **high cross-sectional stability** and is a desirable feature.

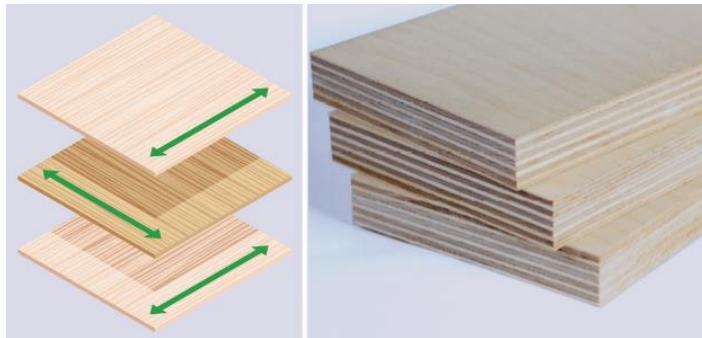

Veneering

A veneer is a thin layer of wood. Plywood is made of layers of veneer laminated together. A veneer can be applied to cheaper materials, such as **medium-density fibreboard** or **chipboard**, to make them appear more expensive.



Use of screws

Screws create a strong joint in timber and can be unscrewed if required. There are two main head designs for screws:

- Flat
- Phillips

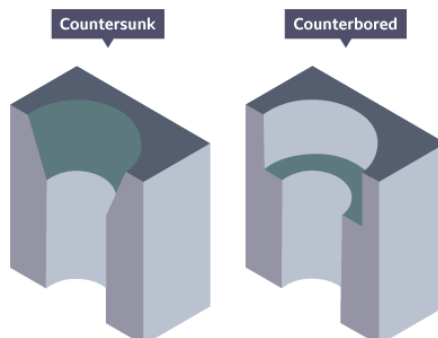

A specific type of screwdriver is required to fit each of the different head designs. Using a countersink hole ensures that the screw lies flat with the timber and stops accidents or things such as clothes becoming entangled on the screw. A **pilot hole** is narrower than the screw thread and makes it easier for the screw to go in.

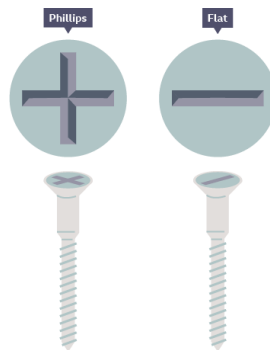

Nailing

Nails come in a range of shapes and sizes, including:

- round wire nails - do not pull through thin timber as they have a large flat head
- panel pins - for holding thin boards onto timber as they are small, often used with adhesive
- oval nails - less likely to split timber as they spread the grain less than round wire nails

A hammer is used to drive a nail through the wood grain and is quicker than fitting a screw. It is common for the nail head to be pushed below the surface of the wood so that it can be covered using a filler and improve the appearance.

Adhesives

PVA and contact adhesive are commonly used when working with wood:

- PVA - commonly used wood glue that is white when wet and dries clear, it takes time to set and must be clamped while the glue sets to produce a permanent and strong join
- contact adhesive - commonly used for sticking different materials onto wood, but care must be taken as it gives off solvent fumes

Wastage

Wastage processes cut materials away to the required shape, eg sawing, **planing**, filing, drilling and sanding. Waste costs money and has an environmental impact, so must be minimised wherever possible.

Addition

Addition processes add materials together - for example, assembling, gluing, screwing and nailing.

Wood joints

Joint	Advantages	Disadvantages
Butt	Quick and easy to make with only glue required	Weak, can break easily, isn't aesthetically pleasing
Dowelled	Can use a jig for accuracy, dowels give the joint good strength	Without the use of a jig it is hard to line up the dowels
Lap	Fairly easy to cut or route	Not very strong, requires glue and panel pins to increase the strength
Housing	Holds a shelf or divider securely within a frame, usually used with lap joints on the corners	Can be difficult to cut on a wide sheet, very accurate marking out and cutting is needed to ensure the shelf is not wonky
Mitre	Commonly used for picture frames, aesthetically pleasing as no end grain is seen	Similar to a butt joint so is weak and often needs reinforcement
Mortise and tenon	Commonly used for joining the legs onto a chair or table, strong joint	Time consuming to cut by hand as the joint is visible and the strength relies on tight-fitting parts
Dovetail	Commonly used for a drawer front that is constantly pulled open, a strong joint, aesthetically pleasing	Difficult to cut by hand

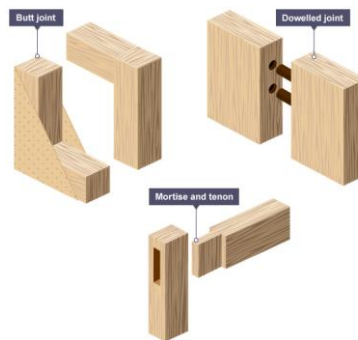

Assembling

Knock-down fittings are a range of standardised fittings commonly used in flat-pack furniture. They allow customers to fit flat-pack furniture together easily, without the need for complex tools and equipment.

Example of a knock-down fitting

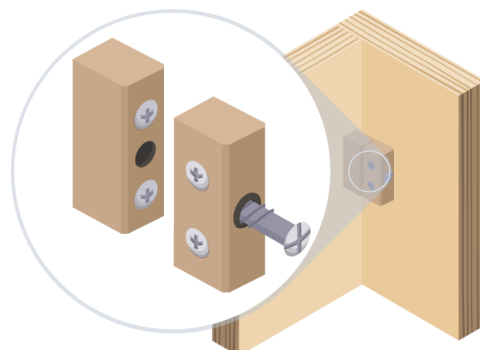

Ironmongery

Ironmongery is a range of parts that can be attached onto products, such as:

- Hinges
- Handles
- Hooks
- drawer runners
- Knobs
- Locks

Hinges

Hinge	Properties	Uses
Butt	Hidden when door is closed, difficult to fit as slot needs to be chiselled out on both sides	Doors
Flush	Easy to fit, leaves a small gap between the door and frame when closed	Small cupboard doors
Butterfly	Often used as decorative feature, easy to fit, the whole hinge is visible	Jewellery boxes, decorative products
T-hinge	Long in length to support excessive weight, the whole hinge is visible	Gates and shed doors

Butt hinge



Surface finishes

Timber can be treated in a variety of different ways and for a variety of different reasons:



Painted timber

Paint

Paint gives colour to the timber and can protect the timber if it is going to go outside. Some paint provides a solid colour - this is called opaque. If the paint is translucent, you can see the grain is visible through the colour. Paints are either **glossy, matt** or **silk**.

Some paint can be applied with a paintbrush or roller; some needs an undercoat so that the timber is sealed before the paint is applied. Most paints will have instructions on the tin to suggest the best method of application, and these will also give details of drying times and necessary health and safety precautions.

Wood stain

Wood stain is applied so that the appearance of the timber is enhanced. It is possible to buy many different wood stains that are designed to look like a different wood type. Often, pine is stained to look like a darker **hardwood** - hardwood is expensive, so staining a piece of cheaper timber is often a good alternative. Wood stain gives some protection to the timber, but an additional coat of varnish after staining is often a good idea.

Oil and wax

Oil and wax soak into timber and can be used to enhance the natural appearance of the timber. Often kitchen worktops and chopping boards are oiled or waxed so that the surface repels water.

Varnish

Varnish can be applied to timber so that a shiny appearance is achieved. Varnish is usually applied in many layers so that the thickness of the varnish is more **durable**. Varnish can be glossy or matt depending on the type used.

Shellac

Shellac is a resin secreted by a beetle. Several layers are built by rubbing the polish on to create a finish called French polish. It tends to be used on expensive furniture to give it a glossy shine but can be easily damaged by heat and water.

Veneering

A **veneer** is a thin layer of wood that can be applied to cheaper materials such as medium-density fibreboard (MDF) or chipboard to make them appear more expensive. A finish will need to be applied to the veneer.

NEA PROJECT SKILLS
INVESTIGATING
DESIGNING
MAKING
EVALUATING
For Both Metal
and Timber
Students

Investigating

During the designing and making processes it is important to gather feedback from the client and users. Refining the product based on this feedback helps solve any problems before production begins.

Identifying design opportunities

Identifying user needs

Identifying the needs and wants of an end user enables a design problem to be clearly formulated. This can be done through:

- Observations
- interviews with a user or user group
- research into the limitations or conditions that your user may face, eg arthritis

Identifying these needs is important so that designers can identify any limitations to ideas and to help with the initial design ideas. Analysis of research and user feedback can lead to changes being made to the brief, such as a change in timescale or budget. The results of feedback, testing and **product analysis** should give the designer a good starting point to adapt, test, evaluate and improve their product throughout the whole **iterative design** process.

Design problem

It is important to outline a design problem and identify a specific need for a product. Without doing this, products are unlikely to be successful in the **market place**.

However, not all design is aimed at selling the maximum number of products. There are many problems that need solving for a very small **target market**, for example:

- designing fastenings for small children to use
- creating products for the partially sighted, which might include bright colours or large buttons
- redesigning products using the ergonomic data of a wheelchair user

Once the needs of the user and design problem have been identified, designers then have the task of designing a product or system to solve the problem. Throughout the **iterative design** process, designers will need to constantly refer back to the [user needs](#) and the design problem to ensure that they are on track.

Existing products

It is important for designers to know what is currently available on the market from their **competitors**. It is valuable for them to know what is already out there, the varying functions, differing prices and customer opinions.

Questions to consider:

- Who are the competitors and what products do they already sell?
- What are the current trends?
- What are the price variations? Are they value for money?
- Which products are good and which are bad? What could be done to make a new product different and better?
- What are the responses from customer reviews?
- What other products could influence the prototype? Designers may take inspiration from the mechanisms of one product and introduce it into the product that they are designing.
- What materials, components and fixings have been used? A **product disassembly** could be beneficial to explore the components inside.
- What have designers done in the past that was successful or unsuccessful?

The product disassembly of a light-emitting diode (LED) bulb



Existing products can be viewed online; however, looking and physically handling products enables designers to experience the products as users would, which is valuable for the **iterative design** process. These findings can be used to inform the [design specification](#).

Designers and design companies

It can sometimes be helpful to look wider than direct competitors. There are [a variety of past and present designers and design companies](#) who have become known for a particular style or approach to design.

Research strategies

A range of research strategies are used by designers to gather relevant information to inform the [design specification](#) and consequently to shape the direction the design process takes, eg research into:

- the market (market research)
- the context
- other possible materials
- relevant **sustainability** issues

Market research

Market research revolves around gathering in-depth information about customer or user needs and preferences. This often involves:

- Looking at products that already exist and talking to clients to collect a wide range of information on what is successful and what needs developing to ensure a product is viable. Interviews and questionnaires can be used to gather information on shape, colour, materials and function of existing products and the answers analysed to improve the product.
- Conducting **focus groups** - Another valuable perspective can be found by talking to the product's **target market**. Small groups can be interviewed, giving feedback before, during and after production, which can be used to improve the outcome.
- Collecting **anthropometric** data about the target market's sizes to help improve designs by making the product easier or more comfortable (ergonomic) to use. Anthropometric data can be used to work out the **dimensions** and **load stresses** of a product.
- Researching into **ergonomics** - Testing and analysing how a person interacts with the product can improve its functionality and how it fits into its surroundings.

Anthropometric data is body measurements



The context

All products are designed to a specification to ensure that it will function correctly within the appropriate context. When exploring the context of a product before designing, the following questions are useful to consider:

- Where will the product be used?
- What conditions will it endure?
- How will it be maintained?

Other possible materials

Designers need to consider the context and the impact this will have on choosing suitable materials:

- What properties are required, eg water or corrosion resistant if the product will be used outside?
- Is there a less common property that can be achieved by using **smart materials**, eg thermochromic and glow-in-the-dark materials?
- What are the different parts and their purpose, eg rubber for grips on handles or blackout linings?

Relevant sustainability issues

It is important for designers to minimise the impact their product will have on the environment, designers sometimes use the 6 Rs to shape their thinking:

1.Repair - Can the product be fixed instead of throwing it away into landfill? Repairing a washing machine can cost a lot less than buying a new one.

2.Reuse - Can the product be passed on or its life extended by using it repeatedly? Reusable carrier bags from the supermarket are a good example.

3.Recycle - Can materials such as metal, plastic and glass be collected and converted? Plastic bottles can be shredded into pellets to make new plastic bottles.

4.Rethink - Can the design be remade using a different material? Using a quick-growing, renewable material such as cotton or bamboo would be better than a non-renewable plastic-based fabric such as polyester.

5.Reduce - Are there products that last longer or can be recharged? Can the miles the product has to travel be cut? Or could **rechargeable batteries** or locally-sourced products be used?

6.Refuse - Thinking twice before buying a product with wasteful packaging or a large carbon footprint.



Product specification

A **design brief** is a short statement that identifies what a designer plans to do, for whom, where it should be used and why they have decided to follow this route - for example, 'to design a workspace for a teenager's bedroom to encourage them to revise and help them to achieve top marks in their exams'.

A **design specification** is a list of criteria your product needs to address. Using the brief as a starting point for research, a specification can be written when more facts are known. Information needs to be found through [research](#). The statements need to be technical, measurable and justified as this then allows them to be used to evaluate the success of the prototype as it is being designed, developed and manufactured through the **iterative design** process.

An example: 'The product must fold away to fit in the cupboard underneath a bedside cabinet (540 mm x 400 mm x 450mm) so that it can be stored easily in the customer's compact and cluttered room.' This statement has been produced from research into the average **dimensions** of a bedside cabinet, it can be used to easily test the iterative **prototypes**, and it is justified, providing reasons about why it is important to the user.

Design specifications should consider:

- **form** - the way that something looks, also called **aesthetics**
- function - what the product will do
- user requirements - [what the user needs from the product](#)
- performance requirements
- material and component requirements - what the product should be made from and the components needed to ensure it functions correctly
- scale of production - how the product is to be manufactured
- cost - affordability, value and profit margins
- maintenance - how the product will be maintained to ensure continued use
- **sustainability** - [minimising the impact on the environment](#)

Designing

Designers use many techniques to create products and solve problems. Design and development involve creating working drawings and parts lists to enable a third party to manufacture the design.

Producing design ideas

Starting with a **design brief**, a designer may come up with a good idea to solve a problem. Using an **iterative design process**, a model can be made from a design sketch and then tested against the criteria in the product specification. The test results may suggest failures and **modifications** required to the design. These changes are evaluated, and then the cycle begins again - until the best solution to the problem is found.

To help the designer arrive at the best solution, design ideas should be questioned and reviewed during the design process. This could include:

- Does it respond to the [design brief](#)?
- Does it meet the criteria set out in the [design specification](#)?
- Can it be manufactured to fit with the budget that has been set and with the ideal selling price?
- Do the **aesthetics** appeal to the user?
- Does it appeal to the users' cultural values?
- Could it be sustainable or easily dismantled to be recycled or reused at the end of its life? Consider materials and [sources of energy](#), eg solar or wind
- How could it be manufactured?
 - Materials
 - **Components**
 - processes and/or techniques

Designers use **annotations** to explain their sketches and models so that other people will clearly understand their design thinking. They also use annotations when communicating their design ideas to address design issues and approaches.

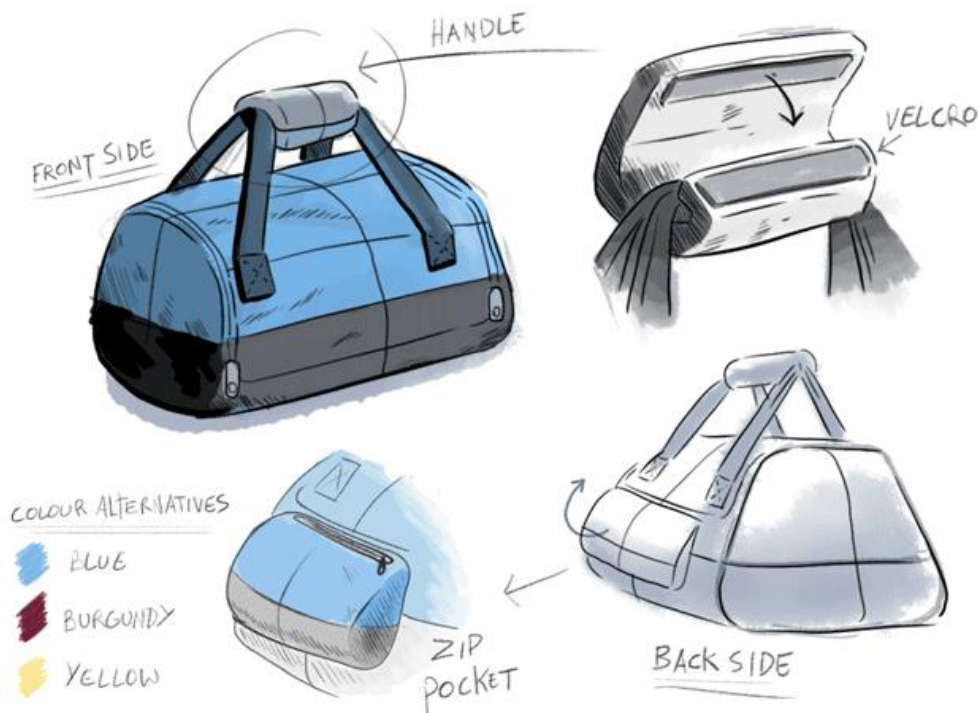

Adding annotations enable designers to justify their design decisions and explain how their ideas work

Reviewing designs

Designers should review and compare their ideas to determine what design to take forward:

- review against the [design brief](#)
- review against the criteria in the [design specification](#)
- ask users for their opinions about the design ideas or models
- ask experts for their opinions about the design ideas or models

Analysis and **evaluation** are a crucial part in the design process as they can highlight any modifications that need to be made at the next stage. It is also a valuable point at which to consider the product against the original design specification and ensure the users' needs are met.

Modifications will be made in relation to the design brief, specification and users' needs to develop their ideas into successful products.

User opinions aid the review of designs and help in making justified design decisions and modifications



Developing ideas

Developmental research

The **iterative design** process helps to develop designs, focusing on improving them and making them more successful. It is important at this stage for designers to consider the design as a whole, rather than the separate **components** in isolation. It is also crucial for designers to consider user feedback in their design decisions as it will help generate and evaluate new developmental ideas and produce a successful chosen design.

Developing ideas will highlight areas of uncertainty that may require further research to strengthen the success of the idea:

- Which areas of the [design specification](#) does the design not meet? What could the designer find out to help meet these criteria?
- Could successful features from other ideas or existing products be merged to make the design more successful?
- How will the product actually work?
 - **mechanisms**, eg ways of opening or moving
 - **components**, eg timers, bulbs, hook and loop fasteners etc.
- How could it be manufactured?
- Are there any potential sustainability issues?
- Are there any potential safety implications or does it comply with standards, eg British Standards Institution (BSI)?
- How could it appeal more to the user?
 - more in-depth research about users, user conditions and values
 - **ergonomic** and **anthropometric** research

Modelling and simulation

Making a model allows designers to visualise and test how a product looks and performs in 3D and is a great way of checking a product's viability.

Modelling can be time-consuming and expensive, but a physical model allows a person to see and handle a product unlike viewing it on a screen through **computer aided design (CAD)**. **computer aided manufacture (CAM)** models made on a 3D printer using a CAD drawing are very accurate but also expensive, time-consuming and limited to 3D-printable materials. Designers can use easy-to-form and easily accessible materials, eg **balsa**, **jelutong** and cardboard, to create cheap models quickly and cheaply.

A 3D model of a bedroom



Quick textile designs can be modelled out of newspaper and more detailed models can be made from cotton or **calico**. Fabric models are called **toiles** and can be made on a **mannequin** to test the **dimensions** and drape of a **garment**.

Breadboards are used in the early development of electronic products. They are boards containing a series of holes that **electrical components** can be pushed into to allow current flow without making a permanent join. Components can then be easily swapped to improve the function before making the final **circuit**.

Prototypes can be full-size, working models of a product, and are the next stage of development after modelling. They are often made from the same material as the product and often have fully **functioning** parts. Prototyping is expensive, so a product needs to have already been modelled and tested.

Reasons for prototyping

- manufacturing plans can be made, allowing for the planning of cost, materials and **quantities**
- following **client** and user feedback, small changes and improvements in **aesthetics** and **function** can be made before production starts
- **user trials** with a prototype can check functionality, marketability and whether a product is fit for purpose before spending money on production
- specialist tools and equipment can be planned for and costed for when the product is later produced for the **mass market**

Prototyping can help work out the cost of manufacturing a product, including how much material is needed and what machinery is required. The percentage profit can be worked out from this and can be improved by lowering production costs, for example by using cheaper materials or fewer workers.

Once a prototype has been made it can be tested in a variety of ways:

- **destructive testing** - tests the product to its extreme to see what conditions it can tolerate before being destroyed, to help decide on the best materials and construction methods to use
- **non-destructive testing** - tests the model to identify areas of weakness without destroying it, to test the function of the product and highlight any unexpected design flaws
- **market testing** - tests the product with its **target market** to give feedback on performance and design

Analysis, evaluation and modifications of design ideas

Throughout the **iterative design** process, the design ideas and models or **prototypes** will need to be **analysed** and **evaluated** to inform the choice of design to take forward, to make modifications and to develop into the final chosen design solution. The designer will also need to consider:

- suitable materials - materials have different **properties** and should be selected appropriately
- suitable techniques and processes - these will be partly defined by the selection of suitable materials
- feedback from users
- [developmental research](#)

These considerations, as well as the **design brief**, **design specification** and feedback from the user, must be constantly utilised to ensure that the designer stays on the right track and produces a successful chosen design.

Communicating ideas

Designers can use a range of communication techniques and media to present their design ideas, such as:

- [freehand sketching \(2D and/or 3D\)](#)
- annotated sketches
- [cut and paste techniques](#)
- [digital photography/media](#)
- [3D models](#)
- [isometric drawings and oblique projections](#)
- [perspective drawing](#)
- [orthographic projections and exploded diagrams](#)
- [assembly drawings](#)
- [system diagrams and schematic diagrams](#)
- [computer aided design \(CAD\) and other specialist computer drawing programs](#)

Designers should choose the appropriate technique according to the type of product they are designing and the stage they are at in the development process. For example, a designer may start off producing design ideas using freehand sketches and then move onto assembly drawings in the design development stage.

Alongside the communication techniques, designers will need to use written techniques to explain and justify their design thinking. This is often done through [annotations](#) and the analysis and evaluation of design ideas.

Making

Manufacturers need to consider the form, function and cost of designs before production. Designers need to consider safety, availability of materials and minimising waste, while maintaining quality.

Meeting the brief

When producing a **prototype**, a designer will need to constantly refer back to the [design brief and design specification](#) to ensure that the prototype fulfils the criteria that it set out to achieve. If, during this process, it does not meet one of the specification statements, then the designer will need to make changes - this is part of the **iterative design** process. If the final prototype does not meet the specification, then it is unlikely to be successful in the market place.

The prototype will need to demonstrate a wide range of making skills that have been conducted by the designer with precision and accuracy. [Precision and accuracy](#) are about being exact. In terms of making, this involves ensuring that parts are measured out correctly and fit together exactly.

Precision in manufacture

Precision can also refer to how materials are cut - **manufacturers** will lose money if too much scrap **raw material** is produced during cutting. Profits could be increased if they are able to find ways to lower the cost per product by saving material. Some manufacturers will pass on the savings that they make to the **consumer** and lower the cost of the product.

Tessellating shapes can help arrange items to be cut so that, when fitted together, as many as possible can be cut out of a sheet of material.

Tessellated shapes



Nesting software will automatically fit irregular shapes as close together as possible. A designer could use a **computer aided design (CAD)** package with built-in nesting tools to try different nested shapes and work out what outputs use the least surface area of material.

Example of nesting

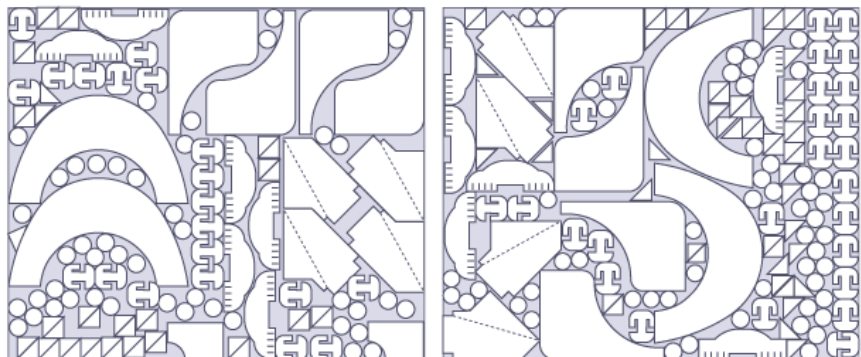

Lay plans are used when cutting fabrics, as fabric has a **nap**. This means that it has a different appearance when viewed in another direction, and that pattern pieces cannot be tessellated or nested as effectively as wood, metal or plastic.

Selecting tools and processes

Each aspect of designing and making features **specialist** tools, which are being developed and improved all the time. Selecting the right tools and equipment for a job is vital when producing a quality product.

Important tips for selecting the most appropriate tools and equipment:

- use Internet research and watch online instruction videos
- access forums and blogs to read public tips on successful production
- ask other people and visit or email specialist workplaces
- visit the local library and research techniques in specialist books
- companies who manufacture the tools and equipment often have detailed instructions online for their use

Material selection

A range of different materials could be used when producing a product, such as:

- [Metals](#)
- [paper and boards](#)
- [Plastics](#)
- [electronic components](#)
- [Textiles](#)
- [Timbers](#)

Materials need to be chosen according to the **properties** that will make them suitable for the required uses of the product. Different materials will require different:

- manufacturing processes (including hand tools and machinery)
- Techniques
- Components
- Fixtures
- Finishes
- Maintenance

Designers are required to think not only about the design and manufacture, but also the use and then the consequent **environmental impact** of the product when it comes to the end of its life.

Surface finishes

Surface finishes can be **functional** or **aesthetic**:

- functional finishes** - can help protect or insulate material, stop **corrosion** and decay, avoid **ultraviolet (UV)** light degradation, stop biological attack from insects or fungus, improve hygiene and can be antibacterial
- aesthetic finishes** - can add decoration or colour and are smooth or textured

Marking out

Accuracy is vital to a quality finished product. The UK recommends the use of metric measurements using millimetres (mm), centimetres (cm) and metres (m).

A datum reference can be along the straight edge of a design, known as datum surface, or a single datum point, often found in the corner of a design. In a circular shape, it would be around the edge or from the centre.

In this example, the opposite corners of the shape are connected with **construction lines** and the intersection creates a reference point in the centre of the work. This is one example of a datum point.

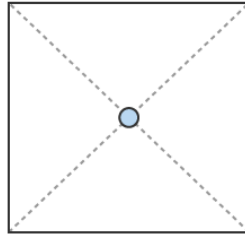

Datum references are particularly useful for aligning **computer aided manufacture (CAM)** machines, which use the point where the X- and Y-axis meet as a datum reference. They can also be used to **scale** sizes up and down in measurements by using the X- and Y-axis.

Jigs are tools made specially to help place a material in the same place repeatedly. They are particularly useful for marking out where holes need to be drilled or joints cut. They cut production costs by saving waste, speeding up the process and improving accuracy. Templates and patterns can be used to ensure that exactly the same shape is being repeated.

Marking-out tools

A range of marking-out tools can be used to show where to cut, drill and assemble parts. Simple marking out can be done with a pencil, but more accurate and consistent markings can be done with:

- **tape measure** - to measure straight and curved shapes
- **pins** - to hold pattern pieces in place and mark points on fabric
- **craft knife** - to cut and score (mark), particularly used on paper and card
- **compass** - to mark out circles
- **scriber** - a sharp point to put a fine scratch on the surface of the metal that is being marked
- **mitre square** - to measure 45 degree and 135 degree angles for mitre joints in picture frames
- **mortise gauge** - to mark out lines parallel to an edge
- **centre punch** - to create a drill point before a hole is drilled so that the drill bit does not slip on the surface
- **engineer's square or try square** - to mark out at 90 degrees to an edge or face
- **marking knife** - to score lines
- **sliding bevel** - can be adjusted to mark a specific angle

Scriver



Health and safety practices

Health and safety

Safe use of tools and materials is vital to everyone in the chain of production. Employers have a duty of care to ensure everyone is adequately trained to use tools and equipment. Personal protective equipment (PPE) must be worn where recommended:

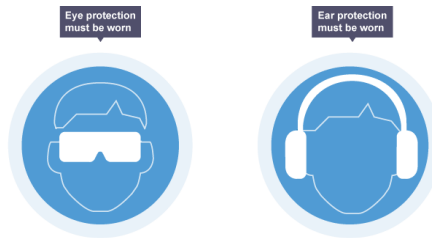

Examples of using PPE:

- protective gloves and aprons for work with heat, eg **brazing** metals
- goggles where there may be splashing or splinters, eg chemical use or using a band saw
- chainmail gloves** when cutting with a fast-moving blade
- a **thimble** to offer protection from puncture wounds when sewing through thick materials by hand
- ear protection when using or working around noisy equipment

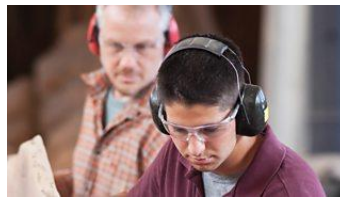

A lot of safe working practice is common sense, such as tying hair back or tucking in loose clothing, but it is important that workers follow the rules set out by their employer:

- machines cannot be left unattended
- all machines need to be fitted with an **isolating switch**, which needs to be switched off when changes are being made, eg swapping a drill bit
- guards and **dust extraction** should be fitted where possible
- work should be clamped down when cutting to avoid the risk of movement
- tools should be stored safely when not in use
- signage must be in place where there may be a health and safety risk
- electrical items need to have passed a **portable appliance test (PAT)** to ensure they are safe to use

Workplaces are required by law to provide **risk assessments** for the use of materials, chemicals and equipment. A risk assessment identifies hazards and what precautions need to be taken to minimise them.

Working safely is a vital part of production. Research into relevant tools, equipment and processes must include checking that they are appropriate and fit for purpose.



These symbols identify the various hazards that are covered by the COSHH (Consideration of Substances Hazardous to Health) regulations, eg the use and storage of corrosive liquids like acid. COSHH reports should be provided by employers for any material considered hazardous to use.

Ensuring quality and accuracy

Quality checks throughout the manufacturing ensure that the end product is functioning and successful

Quality checks to consider include:

- Does it meet all the statements in the [design specification](#)?
- Is it accurate in terms of:
 - **form** or **aesthetics**
 - correct **assembly**
 - consistency between parts
- Does it have high-quality surface finishes?
- Does it function and perform correctly?
- Does it appeal to the user and is it easy to use?
- Is the choice of materials fit for purpose?
- Are the components suitable and functional? This can be tested in many ways, eg using **multimeters** and/or **logic probes** to check that they produce the correct outputs within a circuit.

Designers may find that the quality and accuracy is not to an acceptable standard during the manufacturing process. This may mean that certain ideas, materials or processes need to be modified to create the desired outcome. This does not mean that the design has failed; it is part of the **iterative design** process to make a successful product.

Evaluating

Evaluating ideas, models and feedback is an ongoing process, utilised in continuing to adapt and improve products to make them more useful, appealing and profitable.

Iterative design

Testing

Testing and **evaluating** are not just a ‘tick box’ exercises at the end of manufacture. Testing and evaluation should be continually carried out and used to modify a designer’s ideas throughout the whole **iterative design** process.

It is important for a designer to test their **prototype** against the [design specification](#) by conducting a variety of tests under realistic conditions to ensure that the product is fit for purpose.

Specification statement	Ideas for testing
‘The product should turn on in the dark, using an LDR to prevent a child being scared in the dark.’	Does the LDR work? This can be tested in a dark room. At what light level should the light be activated?
‘The product must fit underneath a standard-sized single bed to be stored when not in use.’	Take the product to a home with a standard-sized single bed and see whether it fits underneath. Does it need to be folded? Is it easy to fold up for storage and unfold for use?

Feedback may be asked from the **client, target market** and other experts in the market. Allowing these groups of people to physically test the product, by handling and using it, will help in gathering useful feedback.

Client feedback

A designer’s initial design may not be exactly what the client had imagined, so feedback is vital to help adapt and improve the product. The client will have a clear idea of what the users of the product, known as the target market group, are looking for and may be able to give the designer feedback about changes they want to be made.

The client may have a particular branding style or a range of existing products that the designer needs to think about or include. As the client is paying for the services of the designer, the client’s wishes should be considered at each stage of the process.

Target market feedback

A group of potential users of the product can be given a prototype to test. These user trials aim to get honest and critical opinions from a range of people.

Expert opinion

Professionals in industry can provide insightful and appropriate feedback. They could have experience of how to make improvements, or how a product can be cheaper or easier to make.

Analysing testing results

To record their findings, designers will take pictures and notes from observations of users operating or wearing their product, as well as gathering users' opinions on this experience. Observing and speaking to a variety of **user groups** and experts allows for more reliable and extensive feedback than that gathered when speaking to just one person. Although analysis is not guaranteed to improve when questioning more people, asking a variety of the right people can be really useful to help change the thought process of a designer and improve the end product.

When numerous people are asked for opinions, it is important to ask questions that can be quantified to provide information that can be **analysed** using spreadsheets and **algorithms**:

- **quantitative data** is information that can be measured and written down with numbers, eg length.

- **qualitative data** is information that cannot be measured and is often based on opinion, eg favourite colour.

Being able to create charts and graphs means data can be looked at quickly and can be shared with other people in a simplified form, as [the data is more visual](#).

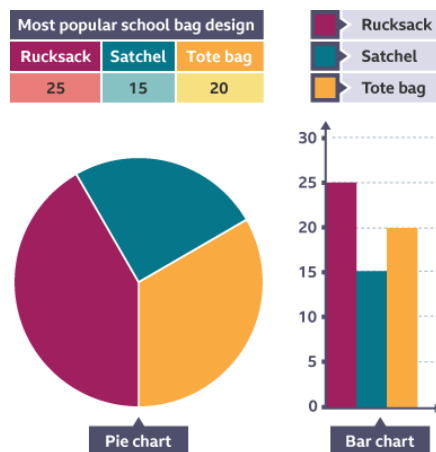

These results will then need to be analysed so that suggestions for modifications and improvements can be put forward in order to make an even more successful product.

Face-to-face or more **conversational interviews** give designers the chance to ask questions and help users form an opinion by offering options for new **iterations**. This qualitative data is also useful in the analysis of prototype testing.

Being able to analyse and reflect on data in a positive way is a key skill of a designer. Working **collaboratively** can help people see the viewpoint of others and improve creativity.

Evaluating against the specification

Designers will have written a **design specification**, developed from the **design brief** and based on the results of completed research. This is where a specific list of **criteria** is written that a designer can follow as a set of rules. During the iterative design process, this specification should be referenced to and designs evaluated against it to ensure the final solution is the best fit.



Considerations might include:

- How does the product fit within the range of sizes specified?
- Does the product fit the client's taste?
- Do the materials and components fit within the specified cost limits?
- Does the product appeal to the **target market**?
- Will the design comply with current safety standards?
- Will the product have a minimal impact on the environment?

Evaluation is part of the **iterative design** process, a circular design process that models, evaluates and improves designs based on the results of testing.

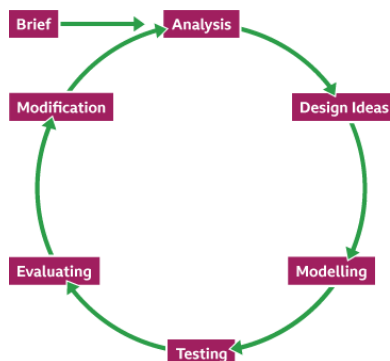

The iterative design process works by **analysing** the feedback received and evaluating against the specification criteria to determine the effectiveness of the product and consequently to redevelop the product. Further improvements can be made and then more feedback can be gathered until both the **client** and the target market are happy with the outcome.

Without the iterative cycle of **evaluation** and improvement from both the client and the target market, the product may not be the best on the market. This will allow another manufacturer to produce a better product that will be more successful.

ANSWERS

Answer 1

Convert 2 minutes into hours:

$$2 \div 60 = 0.03 \text{ hours}$$

Multiply this by the wattage:

$$0.03 \times 750 = \mathbf{22.5 \text{ watts (W)}}$$

Answer 2 - Thermistor

Answer 3 - A tilt switch because it is activated if it detects something is not level.

Answer 4

Mechanical advantage = load \div effort

$$5 = 50 \text{ N} \div \text{effort}$$

This could also be rearranged as from the triangle above.

$$\text{effort} \times 5 = 50 \text{ N}$$

$$\text{effort} = 50 \text{ N} \div 5 = \mathbf{10 \text{ N}}$$

Answer 5

First order - the hand's grip is the applied force, the fulcrum is the pin at the centre of the scissors and the blade applies force to the load.

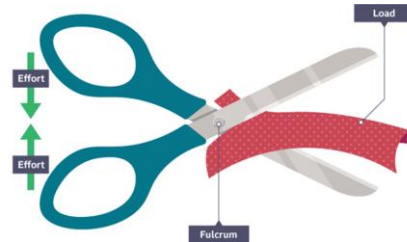

Answer 6

$$C = 35^\circ$$

$$C + A = 180^\circ \text{ and } A = B$$

$$\text{Therefore, } 35^\circ + A = 180^\circ$$

$$180^\circ - 35^\circ = 145^\circ$$

$$A \text{ and } B = \mathbf{145^\circ}$$

Answer 7

$$\text{Gear ratio} = 50 \div 25$$

$$= 2$$

$$\text{Gear ratio} = 2:1$$

Answer 8

Gear ratio = number of teeth on driven gear \div number of teeth on the drive gear
 $= 6 \div 12 = 0.5$

Output speed = input speed \div gear ratio
 $= 120 \div 0.5 = 240 \text{ rpm}$

In this arrangement the output speed is **two times faster** compared to the input speed.

Answer 9

Three sections of rope are taking the strain of the load.

Weight = $300 \div 3$
= 100 N

Answer 10

Velocity ratio = diameter of the driven pulley \div diameter of the driver pulley
 $= 15 \div 150 = \mathbf{0.1}$ or **1:10**

The smaller driver pulley turns ten times for every one turn of the driven pulley.

Output speed = input speed \div velocity ratio
 $= 300 \div 0.1 = \mathbf{3,000 \text{ rpm}}$

The smaller driven pulley will turn at 3,000 rpm. This is the speed that the lawnmower blade will spin at on the lawnmower, ten times faster than the speed of the motor

Answer 11

Weekly costs = labour + workshop hire and energy costs

$\pounds 800.00 + \pounds 300.00 = \pounds 1,100.00$

Profit = selling price - material costs

$\pounds 200.00 - \pounds 45.00 = \pounds 155.00$

Amount to break even in a week = costs per week \div profit

$1,100 \div 155 = 7.09$

Therefore, **eight kennels** need to be sold to cover costs and show a small profit

$\pounds 155.00 \times 8 = \pounds 1,240.00$

$\pounds 1,240.00 - \pounds 1,100.00 = \pounds 140.00$

This yields a profit of **£140.00** each week.

Answer 12

Scale factor = $30 \div 40$ or $60 \div 80$

= 0.75

Also represented as a factor $\frac{3}{4}$ or a ration **3:4**.

Answer 13

Convert the square section into metres:

$$20 \div 1,000 = 0.002 \text{ m}$$

Calculate the surface area of the end:

$$0.002 \text{ m} \times 0.002 \text{ m} = 0.0004 \text{ m}^2$$

The length of the bar is 1 m, so:

$$0.0004 \text{ m}^2 \times 1 \text{ m} = 0.0004 \text{ m}^3$$

The weight per cubic metre (m^3) is 2,600 kg, so:

$$2,600 \times 0.0004 = \mathbf{1.04 \text{ kg}}$$

Answer 14

$$\text{Increase in cost} = \text{£}57.00 - \text{£}45.00 = \text{£}12.00$$

Calculate £12.00 as a percentage of the thicker steel:

$$(12 \div 57) \times 100 = 21$$

So it is **21%** more expensive.

Answer 15

$$1 \text{ m} = 1,000 \text{ mm}$$

$$5\% = 1,000 \times 0.05 = \mathbf{50 \text{ mm}}$$

Range of tolerance = 50 mm either side of the 1 m mark:

$$50 \text{ mm} + 1,000 \text{ mm} = 1,050 \text{ mm maximum}$$

$$1,000 \text{ mm} - 50 \text{ mm} = 950 \text{ mm minimum}$$

$$= \mathbf{100 \text{ mm range}}$$

Answer 16

$$\text{Volume} = 0.65 \text{ m} \times 0.06 \text{ m} \times 0.055 \text{ m} = 0.002 \text{ m}^3$$

$$\text{Total cost} = 0.002 \times 1,850 = \mathbf{\text{£}3.96}$$

Answer 17

Convert sheet to metres:

$$1,220 \text{ mm} = 1.22 \text{ m}$$

$$6,10\text{mm} = 0.61 \text{ m}$$

$$\text{Area of sheet} = 1.22 \text{ m} \times 0.61 \text{ m} = 0.7442 \text{ metres}^2$$

$$\text{Area of plaque} = 0.12 \text{ m} \times 0.24 \text{ m} = 0.0288 \text{ metres}^2$$

$$\text{Area of sheet} \div \text{area of plaque} = 0.7442 \div 0.0288$$

$$= 25.84 \text{ or } \mathbf{25 \text{ whole plaques}}$$

Answer 18

$$1 \text{ m} = 1,000 \text{ mm}$$

$$1\% = 1,000 \div 100 = 10\text{mm}$$

$$\text{Maximum length} = 1,000 \text{ mm} + 10 \text{ mm} = 1,010 \text{ mm}$$

$$\text{Minimum length} = 1,000 \text{ mm} - 10 \text{ mm} = 990 \text{ mm}$$

$$\text{Range of tolerance} = 1,010 \text{ mm} - 990 \text{ mm} = \mathbf{20 \text{ mm}}$$

(If worked in metres, the range of tolerance would be 0.02m)

Tests

Topic Tests – Core Content	Scan QR Code to Access Test
New and Emerging Technologies	
Energy Generation and Storage	
Developments in Modern Materials	
Electronic Systems	
Mechanical Devices	
Material Categories and Properties	

Tests

Topic Tests – Core Content	Scan QR Code to Access Test
Design Contexts	
Environmental, Social and Economic Challenges	
Investigating Past Work	
Design strategies	
Communication of Ideas	

Topic Test - Metal	Scan QR Code to Access Test
Metal	

Tests

Topic Test - Timber	Scan QR Code to Access Test
Timber	
Topic Test – NEA Project Skills	Scan QR Code to Access Test
Investigating	
Designing	
Making	
Evaluating	